

YAMAHA

PARTS CATALOGUE

RD350LC'86 (1UA)

EUROPE

161UA-300E1



FOREWORD

This Parts Catalogue is related to the parts in use for the Yamaha RD350LC '86 (1UA).
When you are ordering replacement parts for the RD350LC '86 (1UA), refer to this Parts Catalogue and quote both part numbers and part names correctly.

1. Modifications or additions which have been made after issue of the Parts Catalogue will be announced in the Yamaha Parts News.
It is advisable that according to the Yamaha Parts News you make necessary corrections to the Parts Catalogue on hand to keep it up-to-date.

2. Abbreviations

The following abbreviations are used in this Parts Catalogue.

- U.R. Use size (thickness) and/or number as required.
- U.N. Use as many as you need.
- A.P. Alternate Parts
- L.M. Local Made
- F# Frame No. (Applicable machine No.)

3. The parts marked with (+) in the parts number column of this Catalogue are not supplied with by Yamaha, those have to be found locally.
4. Parts, which are to be supplied in the form of assemblies, are listed with an indentation of one letter's space, and a dot (.) is put against the name of each part.

EXAMPLE CARBURETOR ASS'Y
 . JET, pilot
 . NOZZLE, main

5. Indication of No. of constituent parts for assembly

The numeral appearing to the right of each constituent part under the description indicates the quantity of such parts for each individual assembly unit.

EXAMPLE

Part No.	Description	Q'ty	Remarks
2F5-83310-60	FRONT FLASHER LIGHT ASS'Y	2	
115-83311-60	. BULB (6V-18W)	1	
1M1-83309-60	. REFLECTOR	1	

6. Initial Serial No. and Color Code

(A) Frame Serial No.	1WT-005101 and following
(B) Engine Serial No.	1WT-005101 and following

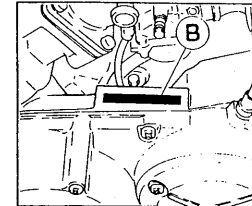
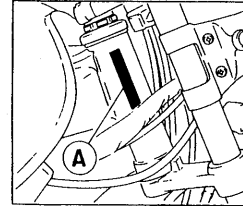

Color Code	Color Name	Abbreviate
GE	Silky White	SW
6G	New Yamaha Black	NYB

7. Applicable colors of graphics are represented in the "Remarks" column by the letter(s) appropriately picked out of the full word(s) showing such colors.

EXAMPLE

Part No.	Description	Q'ty	Remarks
2N4-24110-00-X5	FUEL TANK COMP.	1	MAXIM RED
3J1-24240-10	. GRAPHIC, fuel tank set	1	for MXR

CONTENTS

GENERAL SPEC.

ENGINE

Cylinder	B2 ~ B3
Crankshaft · Piston	B4
Water Pump	B5
Radiator · Hose	B6 ~ B7
Oil Pump	B8 ~ B9
Intake	B10 ~ B11
Carburetor	B12 ~ B13
Exhaust	B14
Crankcase	B15
Crankcase Cover 1	C2
Starter	C3
Clutch	C4 ~ C5
Transmission	C6 ~ C7
Shift Cam · Fork	C8
Shift Shaft	C9

CHASSIS

Frame	C10
Fender	C11
Side Cover	C12 ~ C13
Oil Tank	C14
Rear Arm	C15 ~ D2
Rear Suspension	D3
Steering	D4
Front Fork	D5 ~ D6
Fuel Tank	D7 ~ D8
Seat	D9
Front Wheel	D10
Front Brake Caliper	D11

Rear Wheel	D12 ~ D13
Rear Brake Caliper	D14
Steering Handle · Cable	D15
Front Master Cylinder	E2
Stand · Footrest	E3 ~ E4
Rear Master Cylinder	E5
Generator	E6
Flasher Light	E7
Meter	E8
Headlight	E9
Taillight	E10
Handle Switch · Lever	E11
Electrical 1	E12
Electrical 2	E13

INDEX (GENERAL SPEC.)

Numerical Index	L2 ~ L5
-----------------------	---------

INDIVIDUAL SPEC.

FOR AUSTRIA

Alternate (Engine)	E15
Alternate (Chassis)	F2
Alternate (Electrical)	F3

FOR DENMARK NORWAY

Alternate (Chassis)	F5 ~ F6
Alternate (Electrical)	F7

FOR SWEDEN

Alternate (Engine)	F9
Alternate (Chassis)	F10
Alternate (Electrical)	F11 ~ F12

INDEX (INDIVIDUAL SPEC.)

Numerical Index	M2
-----------------------	----

GENERAL SPEC.

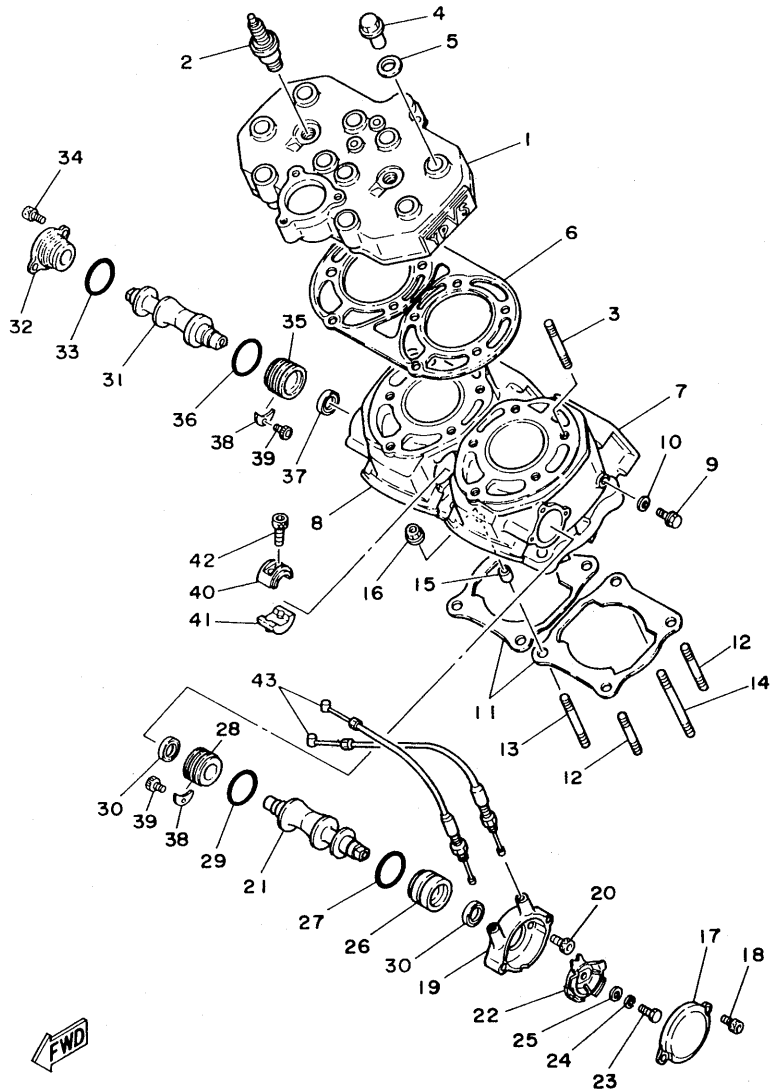

IWT310-6010

FIG. 1 CYLINDER

REF. NO.	PART NO.	DESCRIPTION	Q'TY	REMARKS
1	1UA-11111-01	HEAD, cylinder 1	1	
2	94701-00188	PLUG, spark (NGK BR9ES)	2	
3	90116-08424	BOLT, stud	10	
4	90179-08343	NUT	10	
5	90201-122A7	WASHER, plate	10	
6	31K-11181-00	GASKET, cylinder head 1	1	
7	1UA-11311-00	CYLINDER 1	1	
8	1UA-11321-00	CYLINDER 2	1	
9	95826-06010	BOLT, flange	2	
10	90430-06166	GASKET	2	
11	29L-11351-00	GASKET, cylinder	2	
12	90116-08318	BOLT, stud	4	
13	90116-08388	BOLT, stud	2	
14	90116-08064	BOLT, stud	2	
15	99510-10114	PIN, dowel	4	
16	90179-08299	NUT	8	
17	1UA-1131R-00	CAP, seal	1	
18	91316-05012	BOLT	2	
19	29L-1131M-00	COVER	1	
20	91316-05012	BOLT	2	
21	31K-1131A-00	VALVE 1	1	
22	29L-1132E-00	PULLEY 1	1	
23	97326-06018	BOLT	1	
24	92906-06100	WASHER, spring	1	
25	92906-06600	WASHER, plate	1	
26	31K-1131U-00	HOLDER 3	1	
27	93210-30640	O-RING	1	
28	31K-1131F-00	HOLDER 2	1	

B2

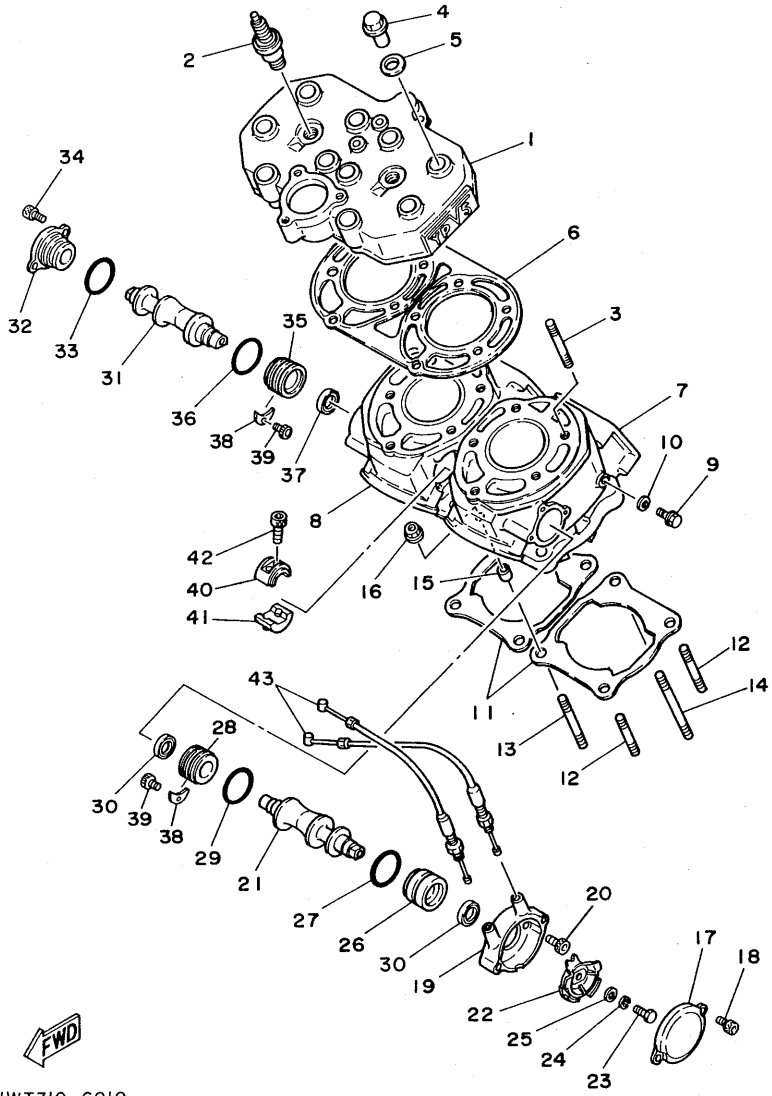

IWT310-6010

FIG. 1 CYLINDER

REF. NO.	PART NO.	DESCRIPTION	Q'TY	REMARKS
29	93210-30734	O-RING	1	
30	93108-23010	OIL SEAL	2	
31	31K-1132A-00	VALVE 2	1	
32	1UA-1131E-00	HOLDER 1	1	
33	93210-30640	O-RING	1	
34	91316-05012	BOLT	2	
35	31K-1131F-00	HOLDER 2	1	
36	93210-30734	O-RING	1	
37	93108-23010	OIL SEAL	1	
38	31K-11915-00	PLATE, thrust 1	2	
39	91316-05010	BOLT	2	
40	29L-1131H-00	JOINT 1	1	
41	29L-1131J-00	JOINT 2	1	
42	91316-04020	BOLT	2	
43	29L-1133E-00	CABLE, pulley 1	2	

B3

FIG. 2 CRANKSHAFT. PISTON

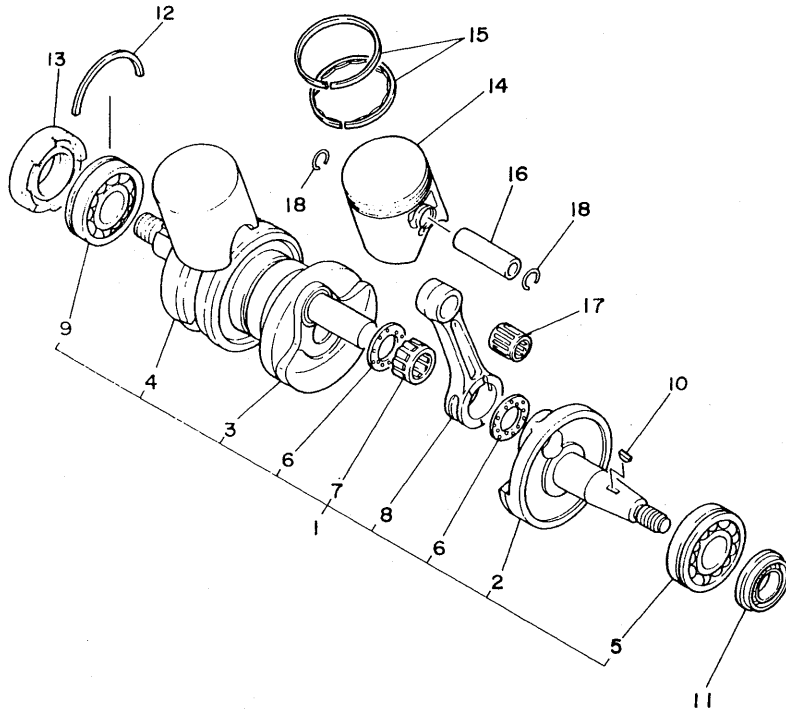

REF. NO.	PART NO.	DESCRIPTION	Q'TY	REMARKS
1	29L-11400-30	CRANKSHAFT ASSY	1	
2	29L-11412-00	.CRANK 1	1	
3	29L-11409-30	.CRANK SUB ASSY	1	
4	29L-11442-10	.CRANK 4	1	
5	93306-30548	.BEARING	1	
6	90209-22292	.WASHER	4	
7	93310-522L4	.BEARING, cylindrical	2	
8	29L-11651-00	.ROD, connecting	2	
9	93306-30549	.BEARING	1	
10	90280-05033	KEY, woodruff	1	
11	93103-25108	OIL SEAL	1	
12	278-17424-01	CIRCLIP 1	1	
13	93103-40077	OIL SEAL	1	
14	1UA-11631-00-94	PISTON (STD)	2	
	1UA-11635-00	PISTON (0.25MM O/S)	2	AP
	1UA-11636-00	PISTON (0.50MM O/S)	2	AP
15	1UA-11610-00	PISTON RING SET (STD)	2	
	1UA-11610-10	PISTON RING SET (1ST O/S)	2	AP
	1UA-11610-20	PISTON RING SET (2ND O/S)	2	AP
16	4L0-11633-00	PIN, piston	2	
17	93310-316H6	BEARING, cylindrical	2	
18	4V2-11634-00	CLIP, piston pin	4	



29L010-3021

B4

FIG. 3 WATER PUMP

REF. NO.	PART NO.	DESCRIPTION	Q'TY	REMARKS
1	4L0-12450-01	IMPELLER SHAFT ASSY	1	
2	93306-30003	BEARING (B6300Z)	1	
3	93103-10147	OIL SEAL	1	
4	93603-22028	PIN, dowel	1	
5	4L0-12459-00	GEAR, impeller shaft	1	
6	99001-07600	CIRCLIP	1	
7	90201-08784	WASHER, plate	1	
8	4L0-12436-00	GEAR, drive	1	
9	4L0-12422-00	COVER, housing	1	
10	4L0-12428-00	GASKET, housing cover 2	1	
11	92501-06014	SCREW, pan head	5	

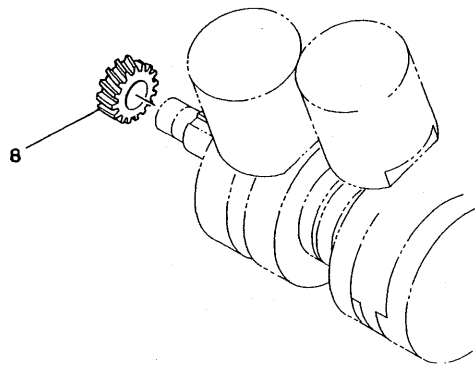
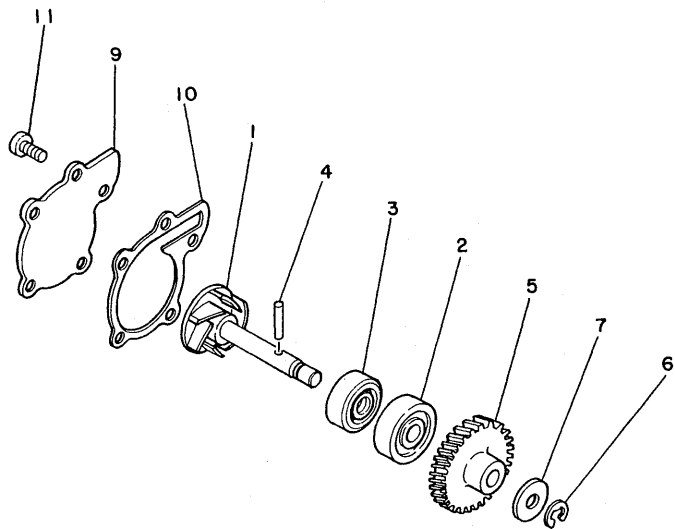

29L010-3040

B5

FIG. 4 RADIATOR. HOSE

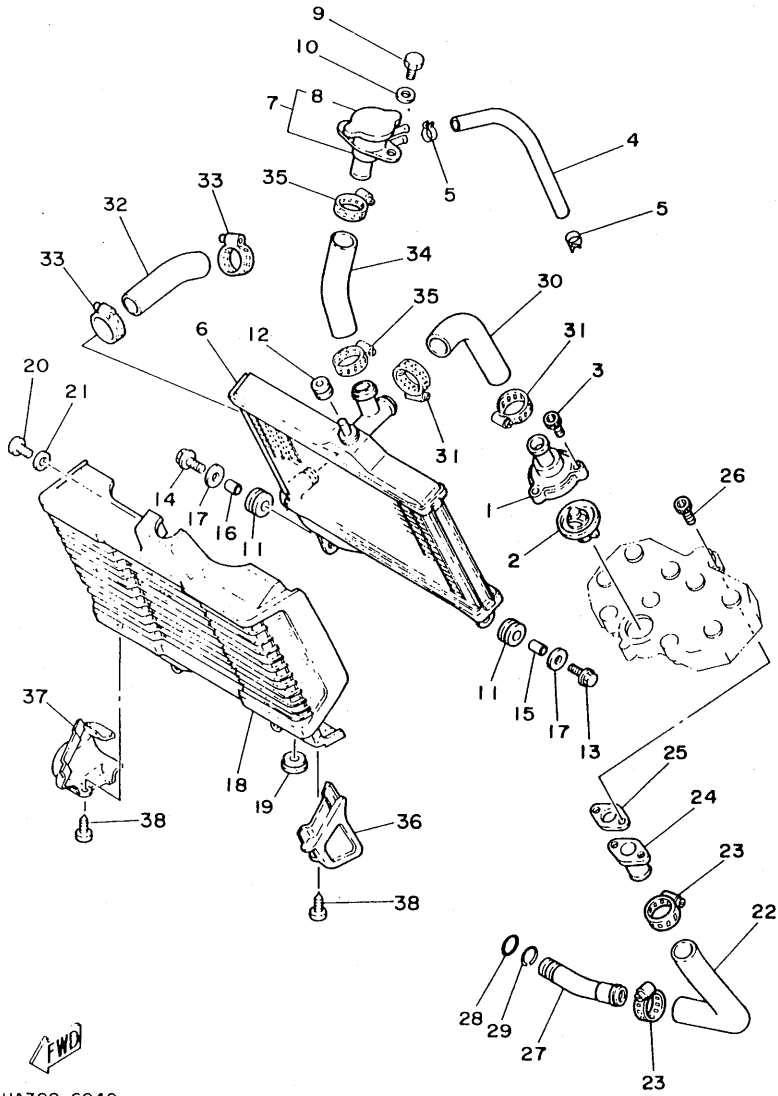

IUA300-6040

REF. NO.	PART NO.	DESCRIPTION	Q'TY	REMARKS
1	29L-12446-00	JOINT	1	
2	29L-12411-00	THERMOSTAT	1	
3	91316-06020	BOLT	3	
4	29L-12485-00	PIPE 5	1	
5	90467-13083	CLIP	2	
6	29L-12461-00	RADIATOR ASSY	1	
7	29L-12590-00	CONDUCTION ASSY	1	
8	22W-12462-00	.CAP, radiator	1	
9	97301-06016	BOLT	2	
10	90201-06067	WASHER, plate	2	
11	90480-15363	GROMMET	2	
12	90480-16284	GROMMET	1	
13	95806-06025	BOLT, flange	1	
14	95806-06020	BOLT, flange	1	
15	90387-07392	COLLAR	1	
16	90387-07390	COLLAR	1	
17	90201-060A3	WASHER, plate	2	
18	29L-12467-00	COVER, radiator	1	
19	90480-12014	GROMMET	2	
20	92506-06016	SCREW, pan head	1	
21	90201-06380	WASHER, plate	1	
22	29L-12481-00	PIPE 1	1	
23	90460-27219	CLAMP, hose	2	
24	4L0-12479-00	JOINT	1	
25	4L0-12435-00	GASKET	1	
26	91316-06020	BOLT	2	
27	29L-12469-00	JOINT 1	1	
28	93210-17239	O-RING	1	

B6

FIG. 4 RADIATOR. HOSE

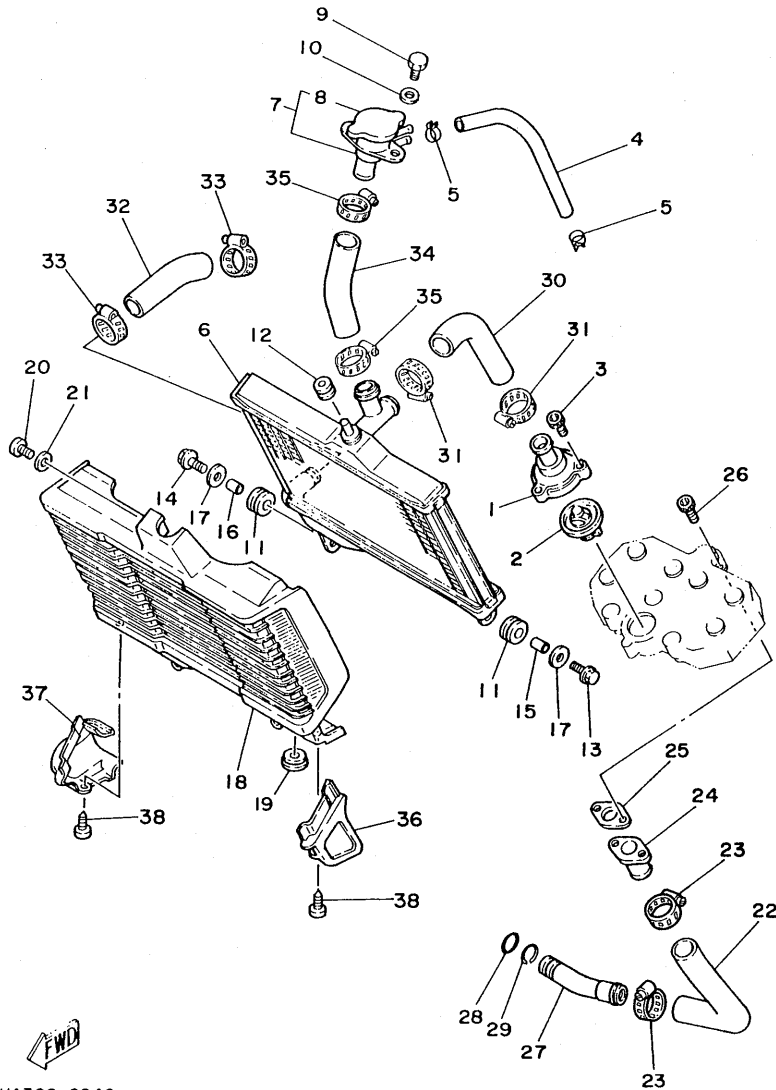

REF. NO.	PART NO.	DESCRIPTION	Q'TY	REMARKS
29	93440-19083	CIRCLIP	1	
30	29L-12482-00	PIPE 2	1	
31	90460-27219	CLAMP, hose	2	
32	4L0-12484-00	PIPE 4	1	
33	90460-27219	CLAMP, hose	2	
34	29L-12483-00	PIPE 3	1	
35	90460-27219	CLAMP, hose	2	
36	29L-1246A-00	COVER 1	1	
37	29L-1246E-00	COVER 2	1	
38	97706-40516	SCREW, tapping	2	

FWD
1UA300-6040

B7

FIG. 5 OIL PUMP

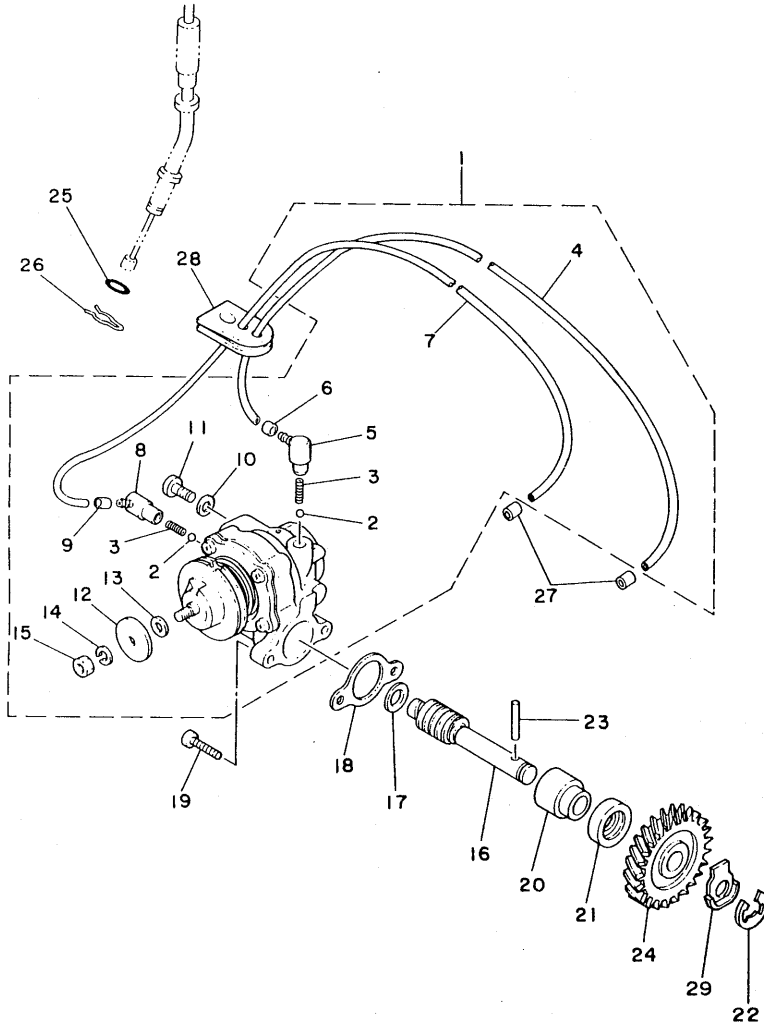

REF. NO.	PART NO.	DESCRIPTION	Q'TY	REMARKS
1	1UA-13101-00	OIL PUMP ASSY	1	
2	93505-32002	.BALL	2	
3	278-13169-00	.SPRING, check ball	2	
4	90445-05203	.HOSE	1	
5	353-13552-01	.NOZZLE	1	
6	90468-02033	.CLIP	1	
7	90445-05765	.HOSE	1	
8	353-13552-01	.NOZZLE	1	
9	90468-02033	.CLIP	1	
10	90430-04004	.GASKET	1	
11	98901-04008	.SCREW, bind	1	
12	137-13138-01	.PLATE, adjusting	1	
13	137-13137-00-03	.SHIM (0.3T)	1	UR
	137-13137-00-05	.SHIM (0.5T)	1	UR
	137-13137-00-10	.SHIM (1.0T)	1	UR
14	92901-05100	.WASHER, spring	1	
15	95301-05600	.NUT	1	
16	4L0-13175-02	SHAFT, worm	1	
17	90201-08624	WASHER, plate	1	
18	8Y0-13116-00	GASKET, pump case	1	
19	98501-05016	SCREW, pan head	2	
20	1E7-13176-00	METAL, worm shaft outer	1	
21	93101-10002	OIL SEAL	1	
22	93430-08036	CIRCLIP	1	
23	93603-22028	PIN, dowel	1	
24	4L0-13178-00	GEAR, pump drive	1	
25	93210-07100	O-RING	1	
26	90468-08086	CLIP	1	



IWT310-6050

B8

FIG. 5 OIL PUMP

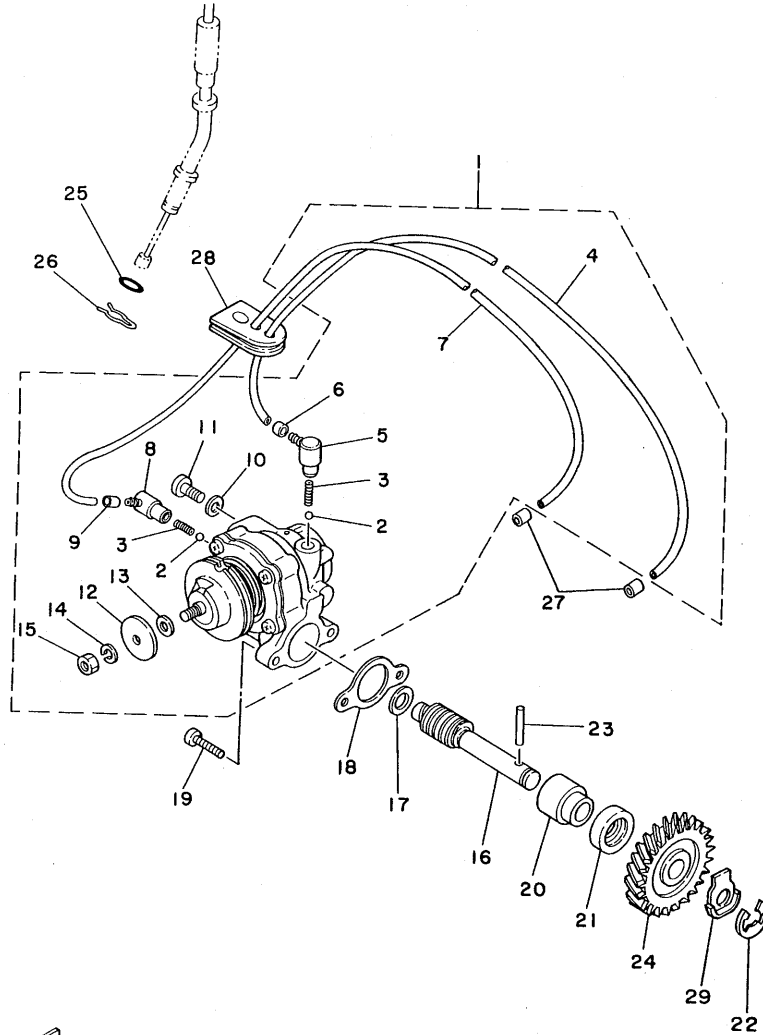

REF. NO.	PART NO.	DESCRIPTION	Q'TY	REMARKS
27	90468-02033	CLIP	2	
28	4L0-13174-00	HOLDER, oil pipe	1	
29	90215-10253	WASHER, lock	1	



IWT310-6050

B9

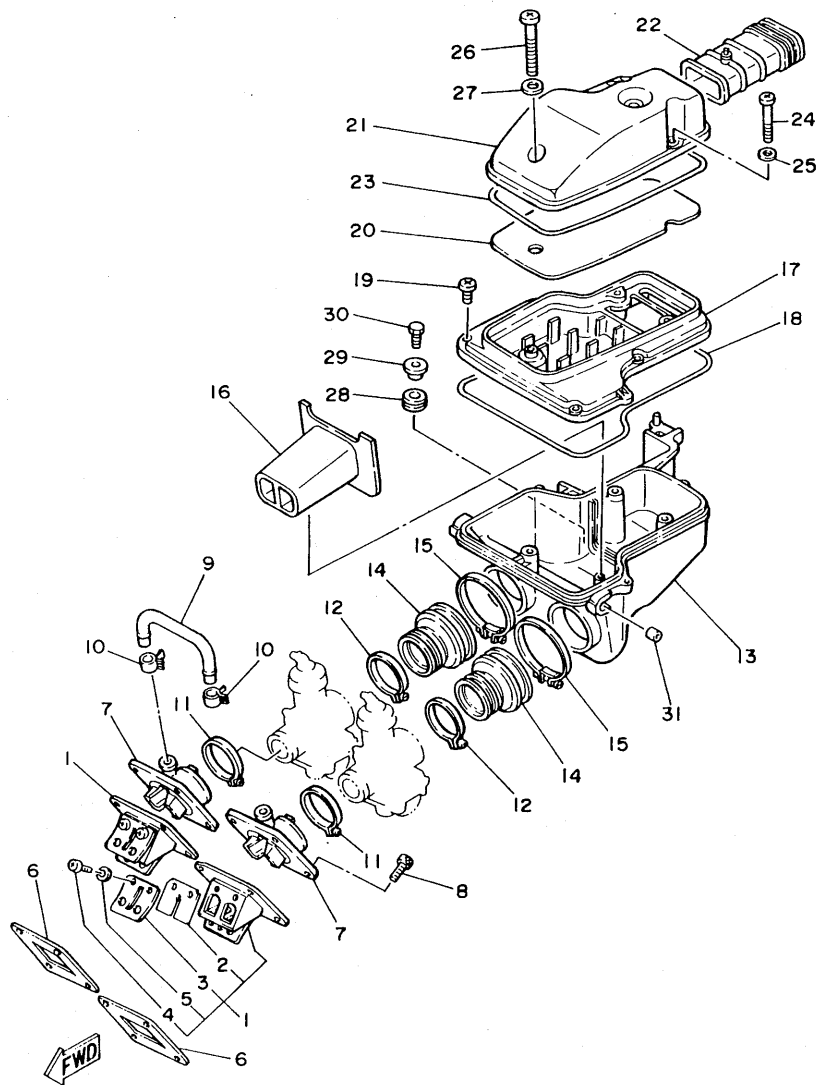

IWT310-6060

FIG. 6 INTAKE

REF. NO.	PART NO.	DESCRIPTION	Q'TY	REMARKS
1	1UA-13610-00	REED VALVE ASSY	2	
2	1UA-13613-00	.REED, valve	2	
3	1UA-13616-00	.STOPPER, reed valve	2	
4	98501-03008	.SCREW, pan head	4	
5	92990-03100	.WASHER, spring	4	
6	31K-13621-00	GASKET, valve seat	2	
7	31K-13565-00	JOINT, carburetor	2	
8	91316-06025	BOLT	8	
9	29L-14465-00	PIPE	1	
10	90467-20085	CLIP	2	
11	90460-44108	CLAMP, hose	2	
12	90460-49058	CLAMP, hose	2	
13	51L-14411-00	CASE, air cleaner 1	1	
14	29L-14453-00	JOINT, air cleaner 1	2	
15	90460-68230	CLAMP, hose	2	
16	51L-1441F-00	PARTITION, air cleaner case	1	
17	29L-14421-00	CASE, air cleaner 2	1	
18	29L-14452-00	SEAL	1	
19	97701-50525	SCREW, tapping	6	
20	29L-14451-00	ELEMENT, air cleaner	1	
21	29L-14412-00	CAP, cleaner case 1	1	
22	29L-14437-00	DUCT	1	
23	11H-14452-00	SEAL	1	
24	92501-06055	SCREW, pan head	2	
25	92901-06600	WASHER, plate	2	
26	92501-06075	SCREW, pan head	1	
27	92901-06600	WASHER, plate	1	
28	90480-16233	GROMMET	1	

B10

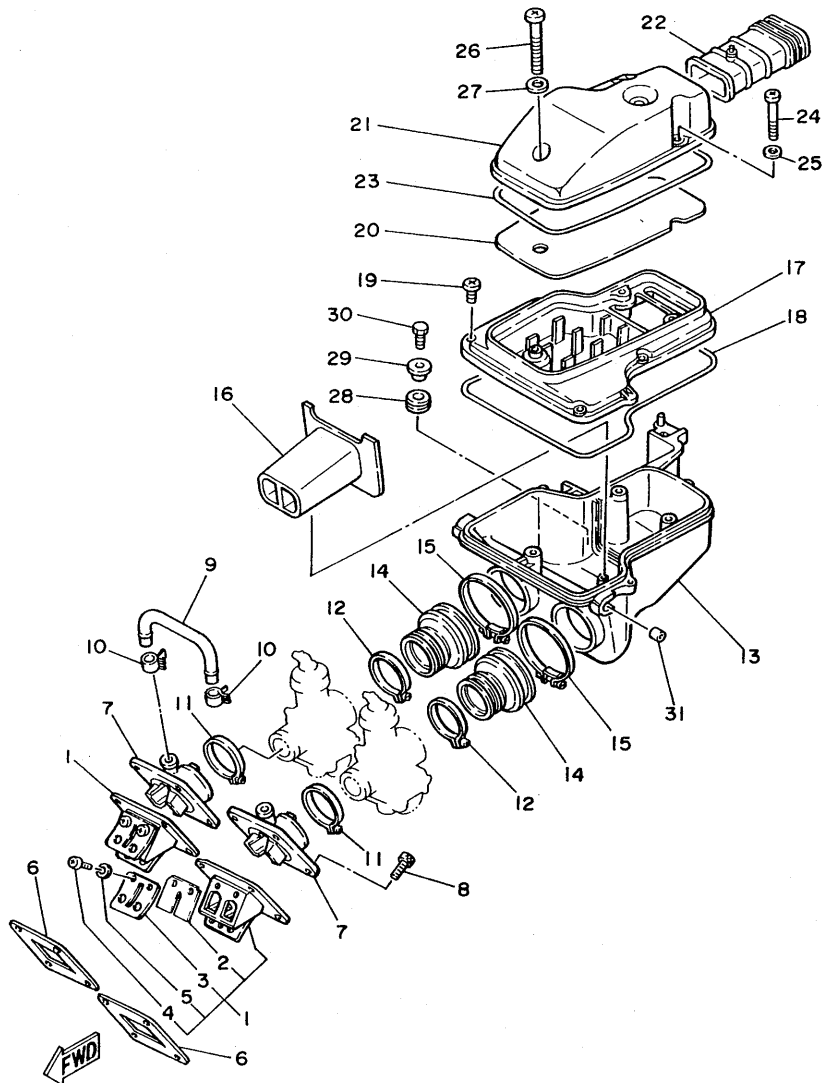

IWT310-6060

FIG. 6 INTAKE

REF. NO.	PART NO.	DESCRIPTION	Q'TY	REMARKS
29	90387-07037	COLLAR	1	
30	97301-06018	BOLT	1	
31	90445-12718	HOSE	2	

B11



IWT310-6070

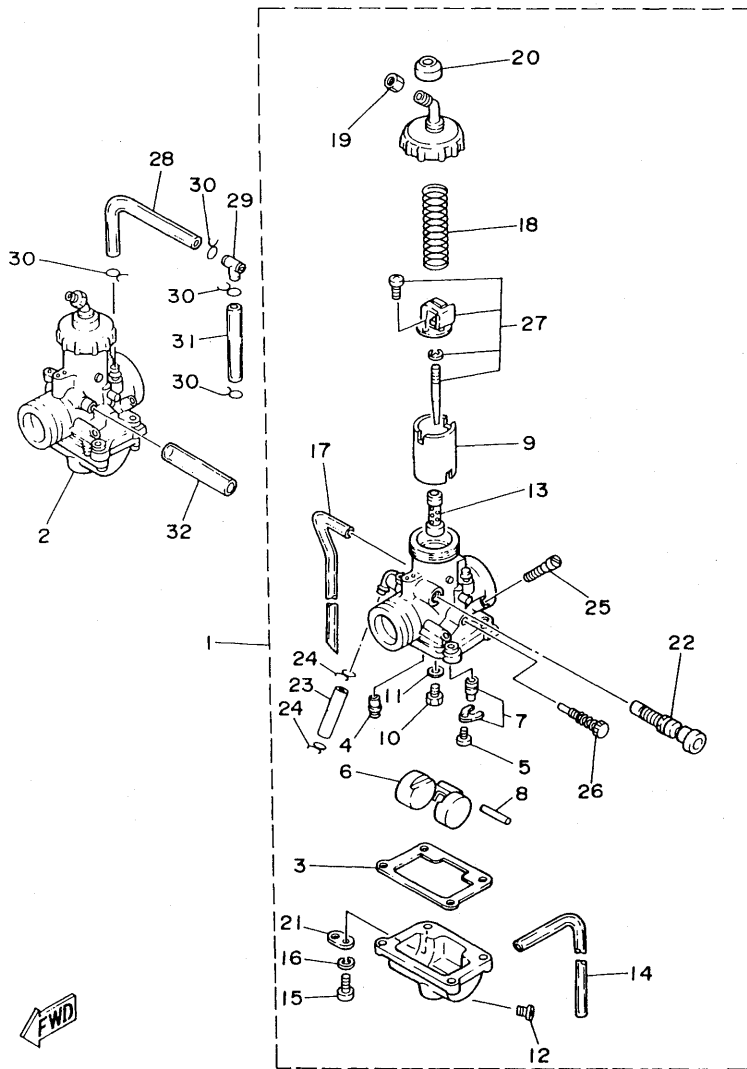
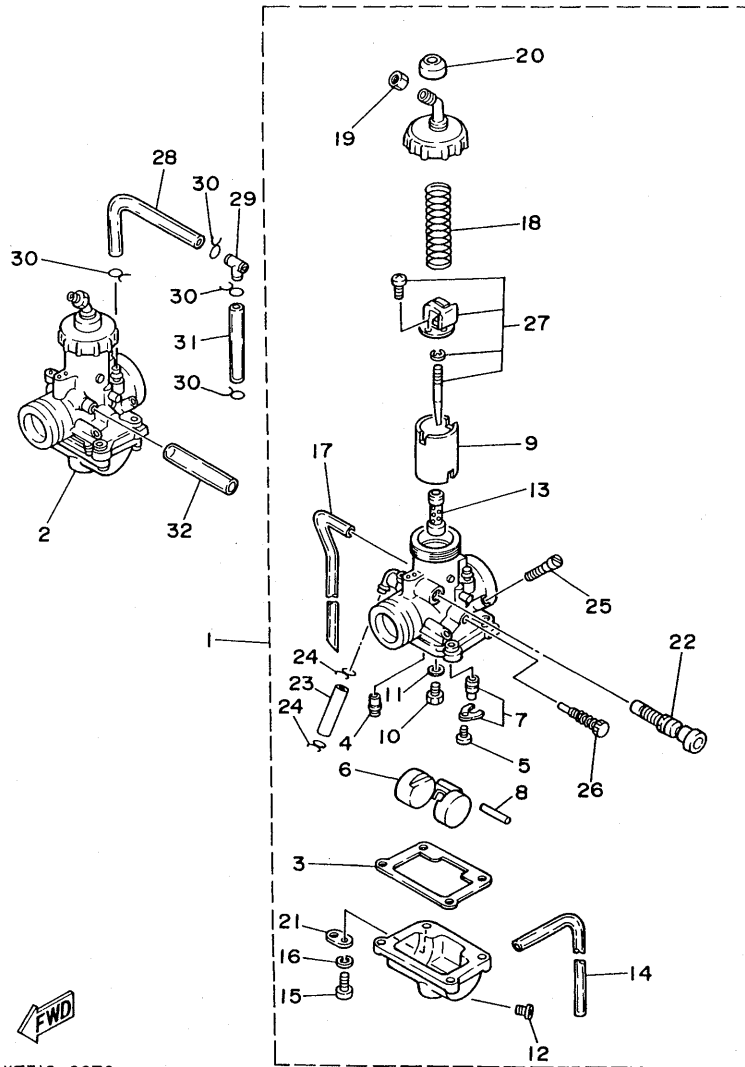

FIG. 7 CARBURETOR

REF. NO.	PART NO.	DESCRIPTION	Q'TY	REMARKS
1	1UA-14101-00	CARBURETOR ASSY 1	1	
2	1UA-14102-00	CARBURETOR ASSY 2	1	
3	304-14184-00	.GASKET, float chamber	1	
4	260-14142-25	.JET, pilot (# 25)	1	
5	98502-04008	.SCREW, pan head	1	
6	4L0-14185-00	.FLOAT	1	
7	48H-14107-28	.NEEDLE VALVE SET	1	
8	537-14186-00	.PIN, float	1	
9	29K-14112-20	.VALVE, throttle 1	1	UR # 1
	29K-14113-20	.VALVE, throttle 2	1	UR # 2
10	137-14143-37	.JET, main (#185)	1	
11	137-14153-00	.WASHER, main jet	1	
12	12R-14191-00	.PLUG, drain	1	
13	1UA-14141-28	.NOZZLE, main	1	
14	4L0-14196-00	.PIPE	1	
15	98511-04016	.SCREW, pan head	4	
16	92902-04100	.WASHER, spring	4	
17	4L0-14197-00	.PIPE	1	
18	4L0-14131-00	.SPRING, throttle valve	1	
19	802-14161-00	.NUT, cable adjusting	1	
20	3X3-14169-00	.CAP	1	
21	500-14146-00	.PLATE	1	
22	4U5-14171-00	.PLUNGER, starter	1	
23	51L-14987-00	.HOSE	1	
24	90467-10008	.CLIP	2	
25	10W-14104-00	.AIR SCREW SET	1	
26	23L-14103-00	.THROTTLE SCREW SET	1	
27	1UA-1490J-00	.NEEDLE SET	1	

B12

FIG. 7 CARBURETOR



REF. NO.	PART NO.	DESCRIPTION	Q'TY	REMARKS
28	29L-24311-00	PIPE, fuel 1	1	
29	90413-07023	WAY 3	1	
30	90467-10041	CLIP	4	
31	90445-11763	HOSE	1	
32	90445-09012	HOSE	1	



IWT310-6070

B13

FIG. 8 EXHAUST

REF. NO.	PART NO.	DESCRIPTION	Q'TY	REMARKS
1	1UA-14710-00	MUFFLER ASSY 1	1	
2	92906-06600	.WASHER, plate	1	
3	90101-06576	.BOLT	1	
4	1UA-14720-00	MUFFLER ASSY 2	1	
5	92906-06600	.WASHER, plate	1	
6	90101-06576	.BOLT	1	
7	90116-08365	BOLT, stud	4	
8	90185-08097	NUT, self-locking	4	
9	29L-14613-00	GASKET, exhaust pipe	2	
10	29L-14643-00	GASKET 3	2	

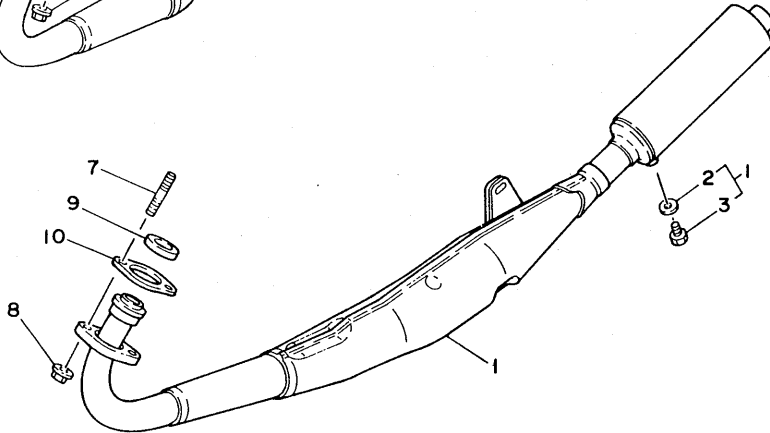
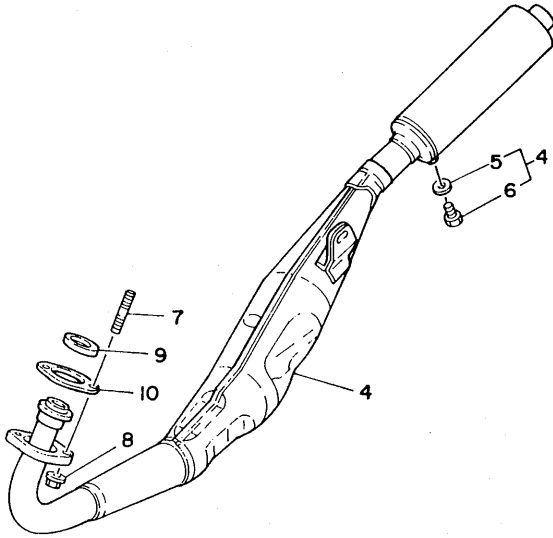

IWT310-6080

B14

FIG. 9 CRANKCASE

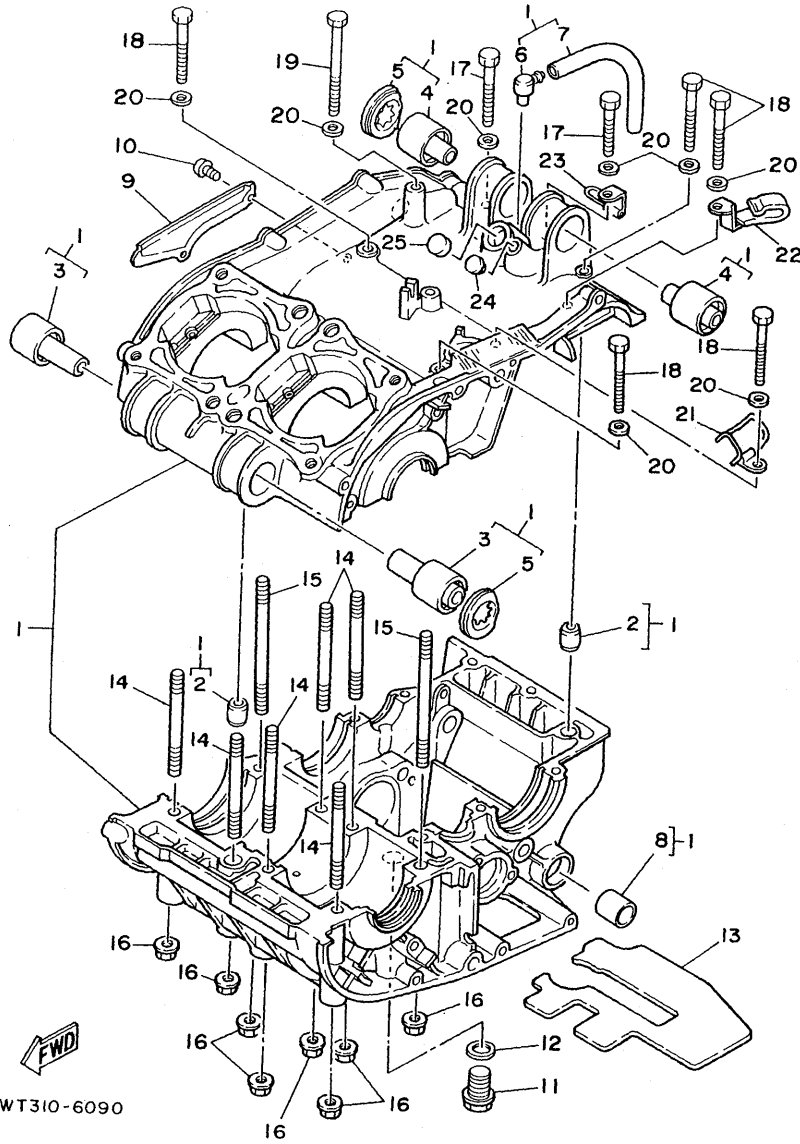

REF. NO.	PART NO.	DESCRIPTION	Q'TY	REMARKS
1	29L-15100-03	CRANKCASE ASSY	1	
2	99510-12016	.PIN, dowel	2	
3	4L0-15316-00	.DAMPER, engine mount 1	2	
4	4L0-15326-00	.DAMPER, engine mount 2	2	
5	4L0-15328-00	.SPACER, damper	2	
6	498-15371-00	.BREATHER	1	
7	90446-07112	.HOSE	1	
8	90383-12022	.BUSH, formed	1	
9	278-15492-01	COVER	1	
10	98501-05010	SCREW, pan head	2	
11	90340-14010	PLUG, straight screw	1	
12	137-15353-00	GASKET, drain	1	
13	48H-15337-00	DAMPER 4	1	
14	90116-08064	BOLT, stud	6	
15	90116-08232	BOLT, stud	2	
16	95701-08500	NUT, flange	8	
17	97311-06045	BOLT	2	
18	97311-06060	BOLT	5	
19	97311-06090	BOLT	1	
20	92901-06200	WASHER, plain	8	
21	90462-16130	CLAMP	1	
22	90465-08125	CLAMP	1	
23	90465-06094	CLAMP	1	
24	90338-05038	PLUG	1	
25	90338-16029	PLUG	1	

IWT310-6090

B15

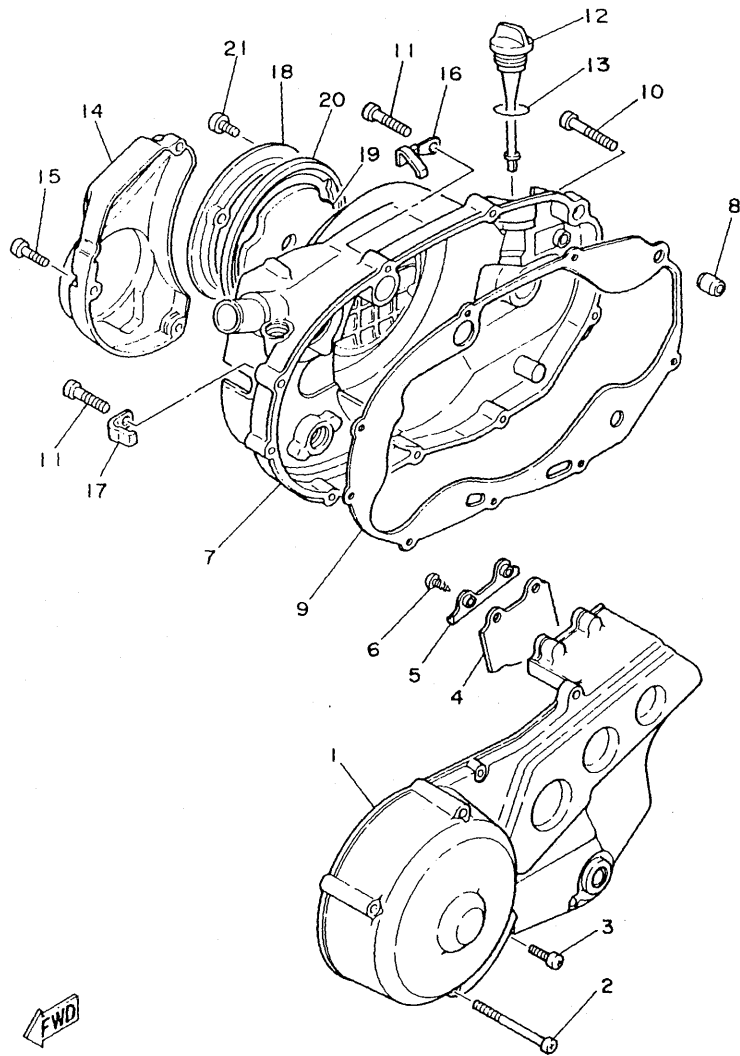

48H110-5100

FIG. 10 CRANKCASE COVER 1

REF. NO.	PART NO.	DESCRIPTION	Q'TY	REMARKS
1	29L-15410-00	CRANKCASE COVER ASSY 1	1	
2	92506-06055	SCREW, pan head	3	
3	92506-06020	SCREW, pan head	4	
4	1A0-15497-00	PLATE, dust seal	1	
5	1A0-15491-00	PROTECTOR	1	
6	97706-50512	SCREW, tapping	2	
7	29L-15421-00	COVER, crankcase 2	1	
8	99510-12016	PIN, dowel	1	
9	4L0-15461-01	GASKET, crankcase cover 2	1	
10	92506-06040	SCREW, pan head	1	
11	92506-06030	SCREW, pan head	8	
12	4L0-15362-00	PLUG, oil level	1	
13	93210-19123	O-RING	1	
14	48H-15420-00	CRANKCASE COVER ASSY 2	1	
15	92506-06020	SCREW, pan head	3	
16	90462-08071	CLAMP	1	
17	90462-08070	CLAMP	1	
18	29L-15431-00	COVER, crankcase 3	1	
19	31K-15317-00	SPACER, engine mount	1	
20	48H-15327-00	SPACER, engine mount	1	
21	98506-05014	SCREW, pan head	3	

FIG. 11 STARTER

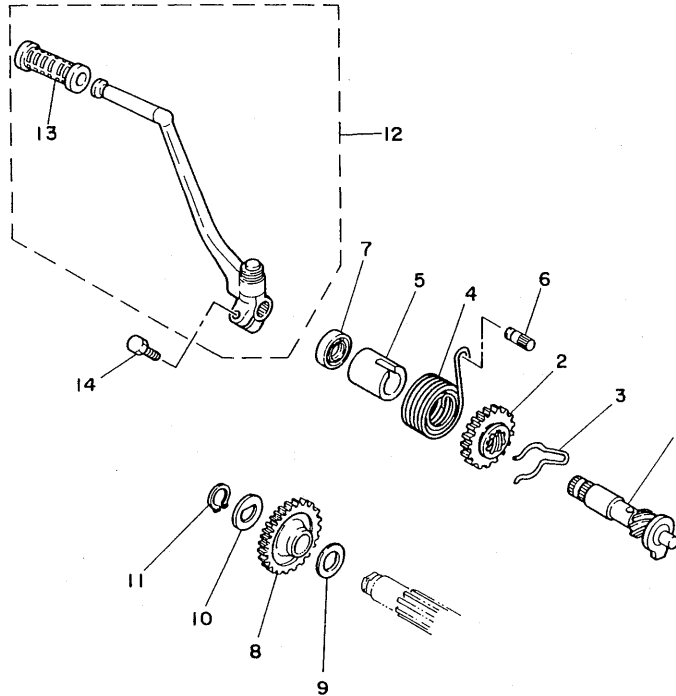

REF. NO.	PART NO.	DESCRIPTION	Q'TY	REMARKS
1	4L0-15660-00	KICK AXLE ASSY	1	
2	4L0-15641-00	GEAR, kick (22T)	1	
3	90468-26091	CLIP	1	
4	90508-30051	SPRING, torsion	1	
5	4L0-15666-00	SPACER	1	
6	248-15668-00	STOPPER	1	
7	93101-20048	OIL SEAL	1	
8	4L0-15651-00	GEAR, kick idle (26T)	1	
9	164-17417-00-10	SHIM 1 (1.0T)	1	UN
10	90214-15020	WASHER, claw	1	
11	99009-15400	CIRCLIP	1	
12	51L-15620-01	KICK CRANK ASSY	1	
13	156-15618-01	.COVER, kick lever	1	
14	97326-08030	BOLT	1	



29L010-3120

C3

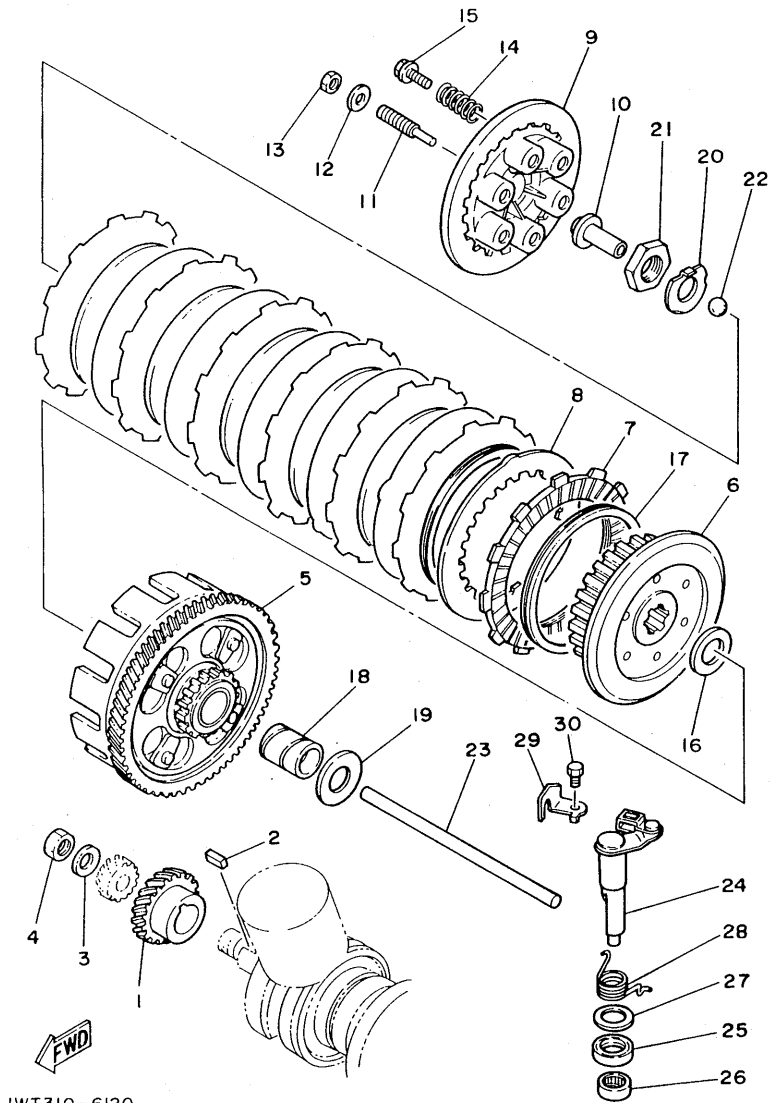

IWT310-6120

FIG. 12 CLUTCH

REF. NO.	PART NO.	DESCRIPTION	Q'TY	REMARKS
1	4L0-16111-00	GEAR, primary drive (23T)	1	
2	90282-07023	KEY, straight	1	
3	90208-16019	WASHER, conical spring	1	
4	90170-16182	NUT	1	
5	31K-16150-10	PRIMARY DRIVEN GEAR COMP.	1	
6	1A0-16371-00	BOSS, clutch	1	
7	4L0-16321-01	PLATE, friction	7	
8	498-16325-00	PLATE, clutch 2	6	
9	29L-16351-00	PLATE, pressure 1	1	
10	29L-16356-00	ROD, push 1	1	
11	90149-08143	SCREW	1	
12	92901-08200	WASHER, plain	1	
13	95311-08700	NUT	1	
14	90501-23138	SPRING, compression	6	
15	90159-06016	SCREW, with washer	6	
16	360-16154-00	PLATE, thrust 1	1	
17	278-16367-00	RING, cushion	7	
18	278-16181-01	SPACER 1	1	
19	360-16154-00	PLATE, thrust 1	1	
20	90215-20223	WASHER, lock	1	
21	90170-20320	NUT	1	
22	93515-32029	BALL	1	
23	29L-16357-00	ROD, push 2	1	
24	29L-16380-00	PUSH LEVER ASSY	1	
25	93102-17004	OIL SEAL	1	
26	93315-11720	BEARING, cylindrical	1	
27	90201-17327	WASHER, plate	1	
28	90508-16599	SPRING, torsion	1	

C4

FIG. 12 CLUTCH

REF. NO.	PART NO.	DESCRIPTION	Q'TY	REMARKS
29	90465-16239	CLAMP	1	
30	97301-06010	BOLT	1	

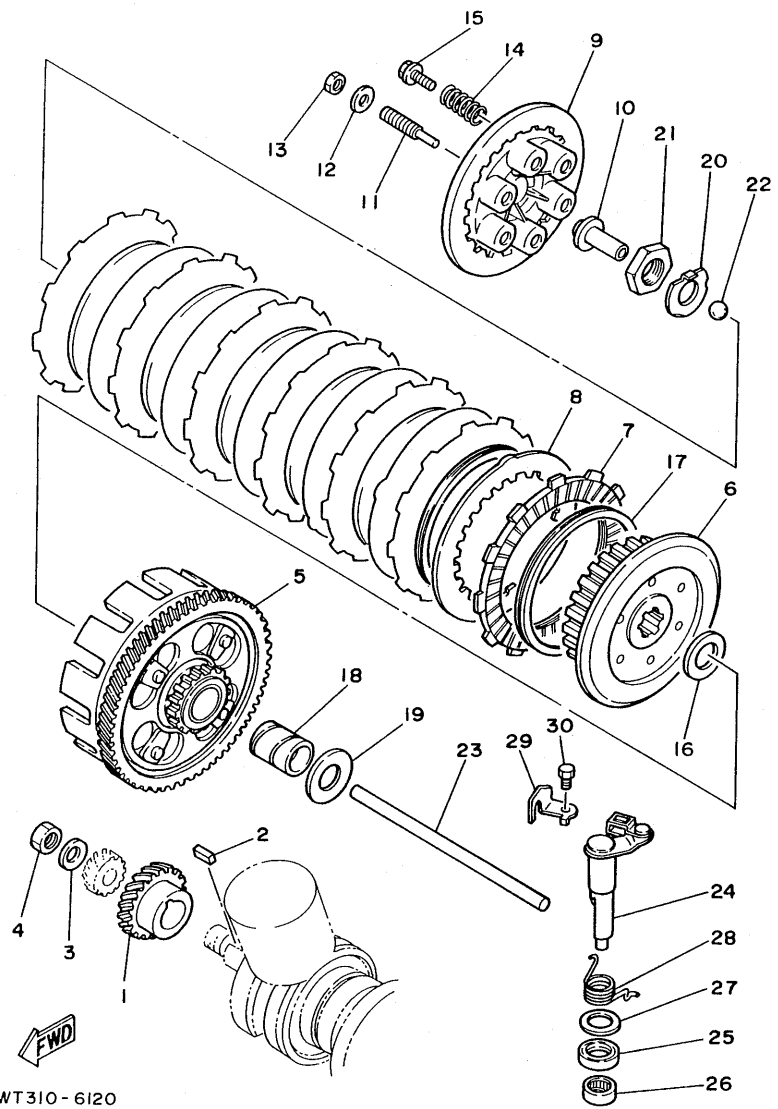

IWT310-6120

C5

FIG. 13 TRANSMISSION

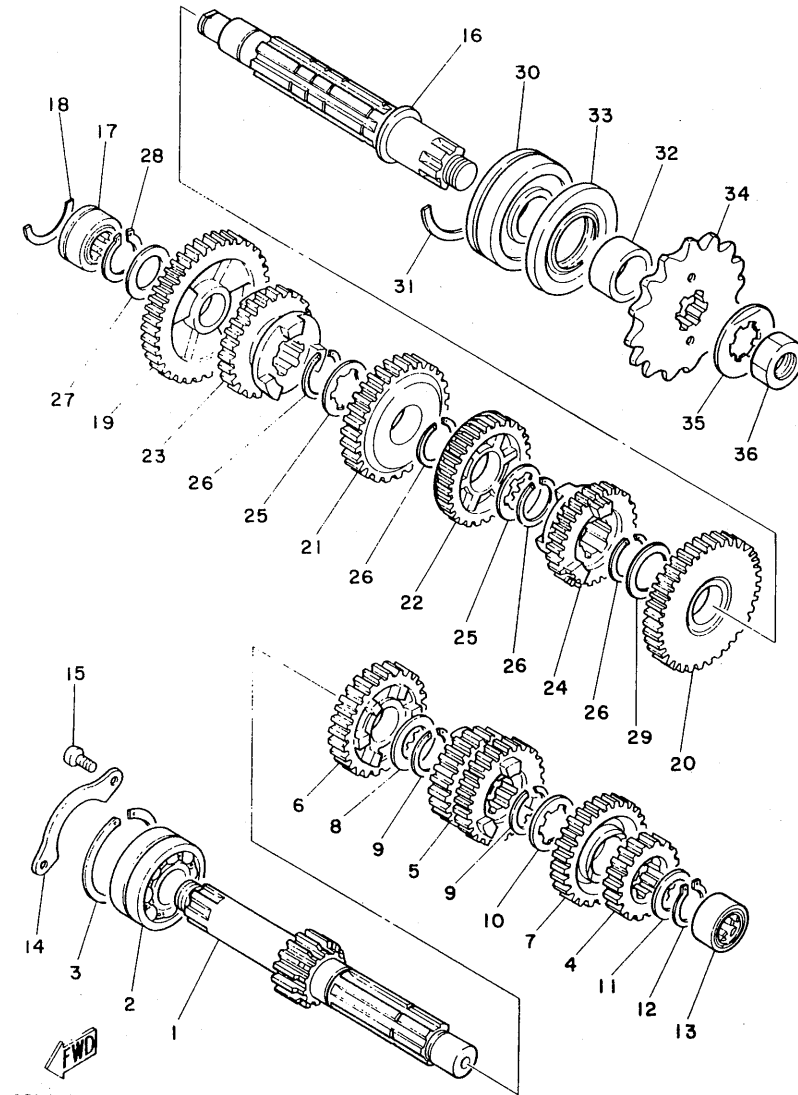

29L010-3140

REF. NO.	PART NO.	DESCRIPTION	Q'TY	REMARKS
1	29L-17411-00	AXLE, main (14T)	1	
2	93305-20502	BEARING (B5205)	1	
3	93440-52009	CIRCLIP	1	
4	29L-17121-00	GEAR, 2nd pinion (18T)	1	
5	29L-17131-00	GEAR, 3rd/4th pinion (22T,24T)	1	
6	29L-17151-00	GEAR, 5th pinion (26T)	1	
7	29L-17161-00	GEAR, 6th pinion (27T)	1	
8	90201-25490	WASHER, plate	1	
9	93440-25084	CIRCLIP	2	
10	90209-21105	WASHER	1	
11	90201-20266	WASHER, plate (1.0T)	1	
12	99009-20400	CIRCLIP	1	
13	93311-22027	BEARING, cylindrical	1	
14	4L0-17471-00	PLATE, cover	1	
15	92501-06012	SCREW, pan head	2	
16	29L-17421-00	AXLE, drive	1	
17	93311-42045	BEARING, cylindrical	1	
18	278-17425-00	CIRCLIP 2	1	
19	4L0-17211-01	GEAR, 1st wheel (36T)	1	
20	4L0-17221-01	GEAR, 2nd wheel (32T)	1	
21	29L-17231-00	GEAR, 3rd wheel (29T)	1	
22	4L0-17241-01	GEAR, 4th wheel (26T)	1	
23	29L-17251-10	GEAR, 5th wheel (25T)	1	
24	29L-17261-10	GEAR, 6th wheel (24T)	1	
25	90209-21105	WASHER	2	
26	93440-25084	CIRCLIP	4	
27	90201-20276	WASHER, plate (1.0T)	1	
28	99009-20400	CIRCLIP	1	

C6

FIG. 13 TRANSMISSION

REF. NO.	PART NO.	DESCRIPTION	Q'TY	REMARKS
29	90201-25490	WASHER, plate	1	
30	93306-30504	BEARING (B6305N)	1	
31	278-17424-01	CIRCLIP 1	1	
32	90387-257N4	COLLAR	1	
33	93102-35369	OIL SEAL	1	
34	1M1-17461-70	SPROCKET, drive (17T)	1	
35	90215-21239	WASHER, lock	1	
36	90179-18020	NUT	1	

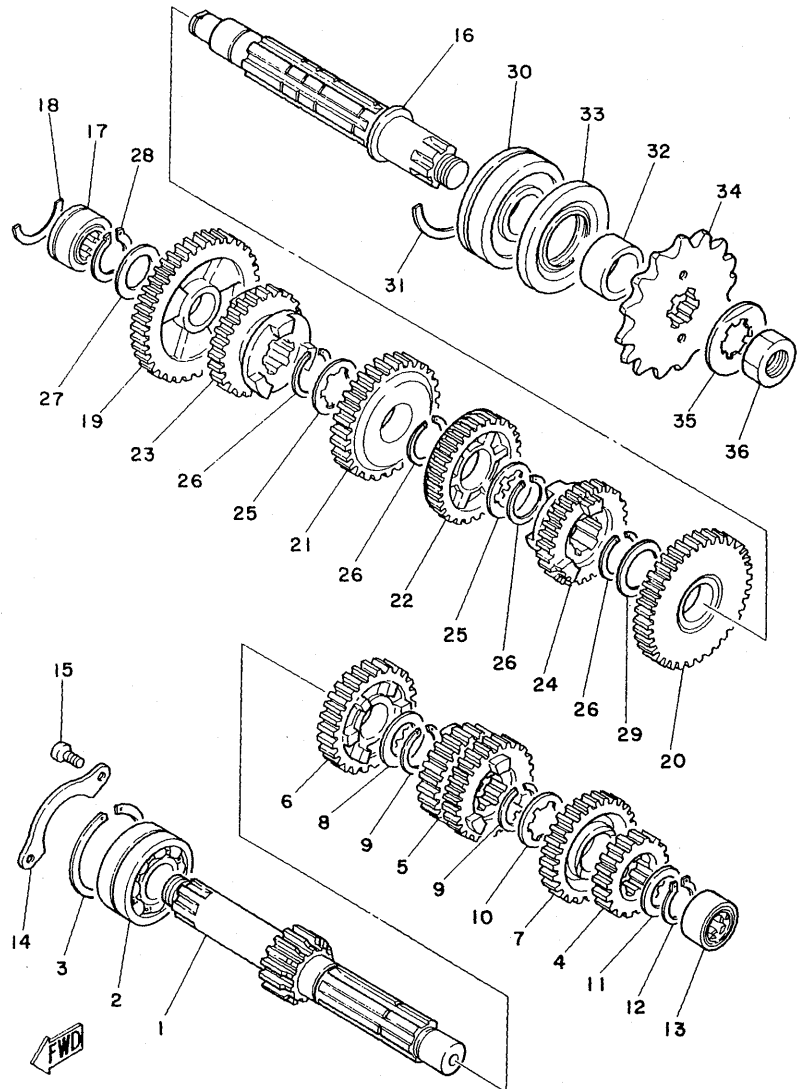

29L010-3140

C7

FIG. 14 SHIFT CAM. FORK

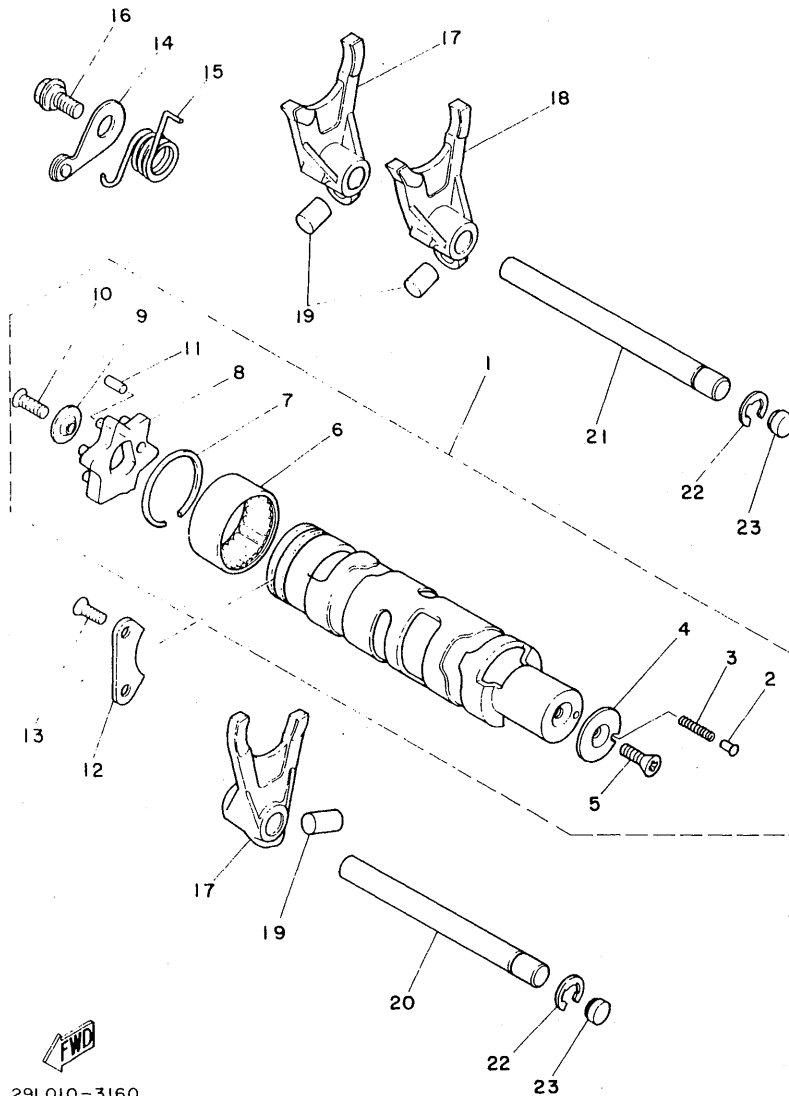

29L010-3160

REF. NO.	PART NO.	DESCRIPTION	Q'TY	REMARKS
1	29L-18540-00	SHIFT CAM ASSY	1	
2	278-18542-00	.POINT, neutral	1	
3	90501-06022	.SPRING, compression	1	
4	278-18566-00	.PLATE, side 2	1	
5	98701-05012	.SCREW, flat head	1	
6	93315-23612	.BEARING, cylindrical	1	
7	93440-34025	.CIRCLIP	1	
8	4L0-18185-00	.SEGMENT	1	
9	3R4-18561-00	.PLATE, side 1	1	
10	98701-05016	.SCREW, flat head	1	
11	93604-12037	.PIN, dowel	1	
12	4L0-18562-00	PLATE, stopper 2	1	
13	92701-06015	SCREW, flat head	2	
14	4L0-18140-00	STOPPER LEVER ASSY	1	
15	90508-26452	SPRING, torsion	1	
16	1W1-18177-00	BOLT, stopper	1	
17	4L0-18511-00	FORK, shift 1	2	
18	4L0-18512-00	FORK, shift 2	1	
19	90250-08017	PIN, straight	3	
20	4L0-18531-01	BAR, shift fork guide 1	1	
21	29L-18535-00	BAR, shift fork guide 2	1	
22	93430-08036	CIRCLIP	2	
23	90334-10014	PLUG, straight	2	

FIG. 15 SHIFT SHAFT

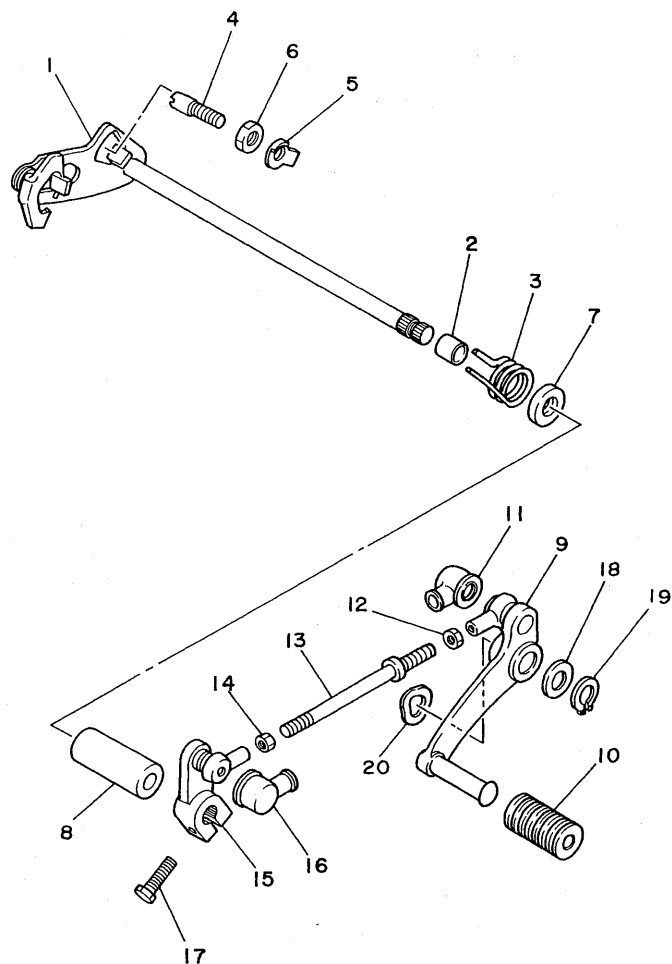

REF. NO.	PART NO.	DESCRIPTION	Q'TY	REMARKS
1	4L0-18101-00	SHIFT SHAFT ASSY	1	
2	90560-12171	SPACER	1	
3	90508-32374	SPRING, torsion	1	
4	90149-08094	SCREW	1	
5	90215-08174	WASHER, lock	1	
6	90170-08029	NUT	1	
7	93102-12106	OIL SEAL	1	
8	90387-125A8	COLLAR	1	
9	1UA-18111-00	PEDAL, shift	1	
10	132-18113-01	COVER, shift pedal	1	
11	2H9-18154-00	COVER, dust	1	
12	95306-06700	NUT	1	
13	1UA-18115-00	ROD, shift	1	
14	90170-06289	NUT	1	
15	1UA-18112-00	ARM, shift	1	
16	2H9-18154-00	COVER, dust	1	
17	97316-06020	BOLT	1	
18	90201-122A7	WASHER, plate	1	
19	99009-12400	CIRCLIP	1	
20	90206-12074	WASHER, wave	1	

IWT310-6150

C9

FIG. 16 FRAME

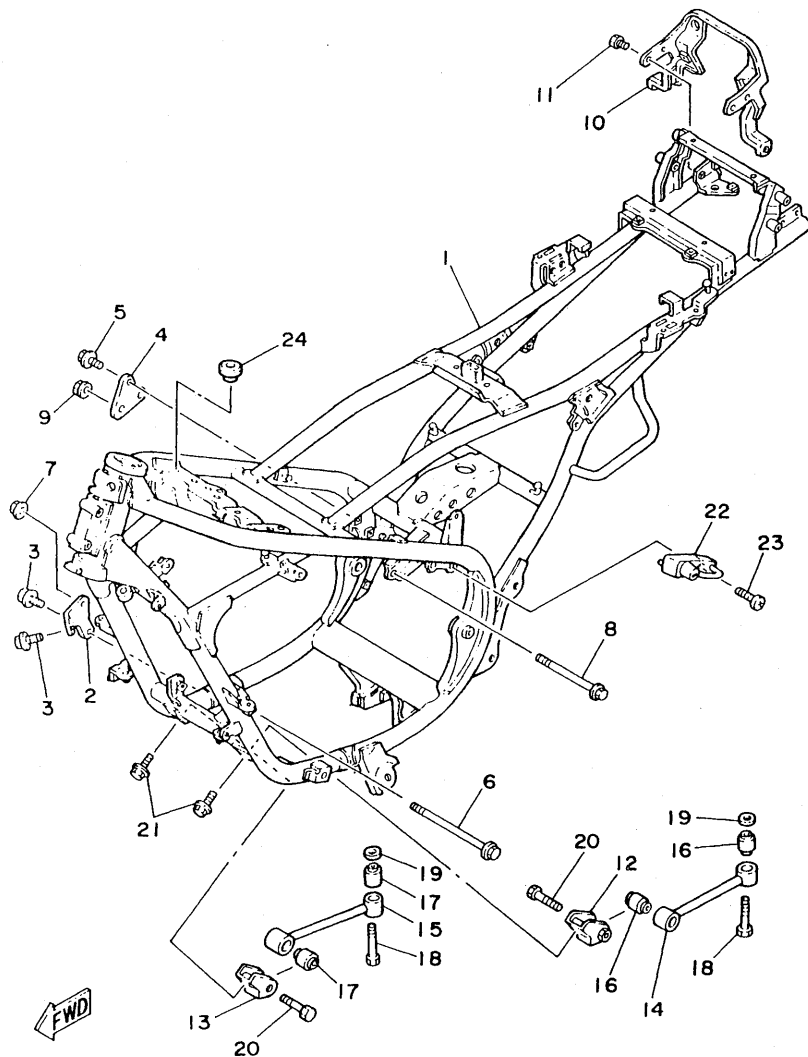

IUA300-6160

REF. NO.	PART NO.	DESCRIPTION	Q'TY	REMARKS
1	1WT-21110-00-33	FRAME COMP.	1	YAMAHA BLACK
2	29L-21315-01	STAY, engine 2	1	
3	95021-08016	BOLT, flange	2	
4	29L-21316-00	STAY, engine 3	1	
5	95021-08016	BOLT, flange	2	
6	95021-10150	BOLT, flange	1	
7	95701-10500	NUT, flange	1	
8	95021-10115	BOLT, flange	1	
9	95701-10500	NUT, flange	1	
10	1UA-21260-00	REAR FENDER BRACKET COMP.	1	
11	98002-06010	BOLT	4	
12	4L0-21317-00	STAY, engine 4	1	
13	4L0-21318-00	STAY, engine 5	1	
14	1UA-21314-00	STAY, engine 1	1	
15	1UA-21319-00	STAY, engine 6	1	
16	4L0-21485-00	DAMPER, rubber 1	2	
17	4L0-21485-00	DAMPER, rubber 1	2	
18	98001-10040	BOLT	2	
19	92990-10600	WASHER, plate	2	
20	98001-10040	BOLT	2	
21	95806-08012	BOLT, flange	2	
22	47X-21308-00	HELMET HANGER ASSY	1	
23	90149-06154	SCREW	1	
24	137-24181-00	DAMPER, locating 1	1	

C10

FIG. 17 FENDER

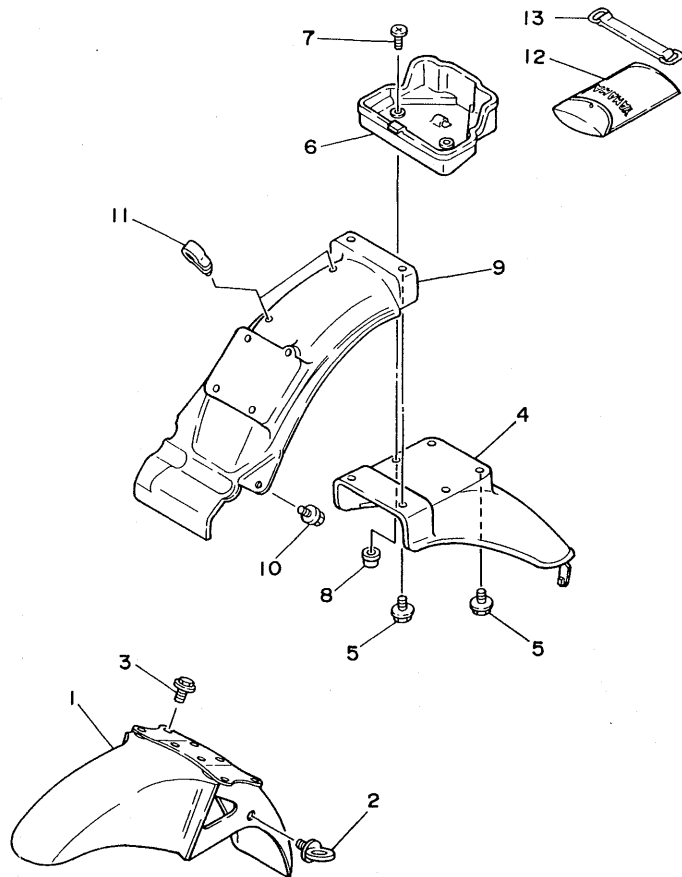

REF. NO.	PART NO.	DESCRIPTION	Q'TY	REMARKS
1	51L-21510-00-7X	FRONT FENDER COMP.	1	UR SILKY WHITE
	51L-21510-00-8X	FRONT FENDER COMP.	1	UR NEW YAMAHA BLACK
2	1A8-21518-00	HOLDER, cable	1	
3	95023-06016	BOLT, flange	4	
4	1UA-21610-00	REAR FENDER COMP.	1	
5	90119-06044	BOLT, with washer	4	
6	1UA-21171-00	BOX, tool	1	
7	98906-05016	SCREW, bind	2	
8	90179-05523	NUT	2	
9	29L-21629-00	GUARD, mud	1	
10	90119-06095	BOLT, with washer	1	
11	90464-12027	CLAMP	2	
12	1UA-28100-00	TOOL KIT	1	
13	116-82131-00	BAND, battery	1	



IWT310-6170

C11

FIG. 18 SIDE COVER

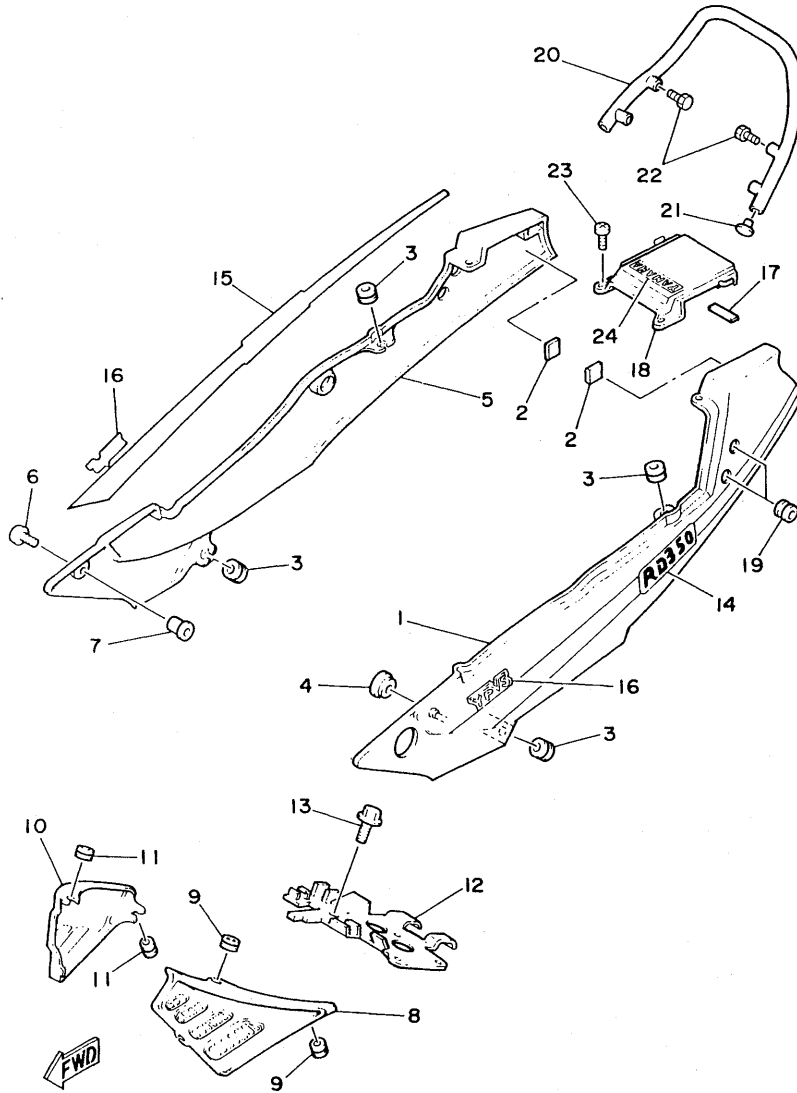

IUA300-6180

REF. NO.	PART NO.	DESCRIPTION	Q'TY	REMARKS
1	1UA-21711-00-GE	COVER, side 1	1	UR SILKY WHITE
	1UA-21711-00-6G	COVER, side 1	1	UR NEW YAMAHA BLACK
2	4J2-21778-00	DAMPER, locating 1	2	
3	90480-12053	GROMMET	4	
4	90480-13426	GROMMET	1	
5	1UA-21721-00-GE	COVER, side 2	1	UR SILKY WHITE
	1UA-21721-00-6G	COVER, side 2	1	UR NEW YAMAHA BLACK
6	90110-06090	BOLT, hexagon socket head	1	
7	90179-06520	NUT	1	
8	29L-21731-00	COVER, side 3	1	
9	90480-12014	GROMMET	2	
10	29L-21741-00	COVER, side 4	1	
11	90480-12014	GROMMET	2	
12	1UA-21243-00	PLATE, bridge	1	
13	90119-06042	BOLT, with washer	2	
14	1WT-2173E-00	GRAPHIC 1	1	UR FOR SW
	1WT-2173E-20	GRAPHIC 1	1	UR FOR NYB
15	1WT-2173F-00	GRAPHIC 2	1	UR FOR SW
	1WT-2173F-20	GRAPHIC 2	1	UR FOR NYB
16	1UA-21786-00	EMBLEM 6	2	UR FOR SW
	1UA-21786-10	EMBLEM 6	2	UR FOR NYB
17	50W-2639G-00	SEAL	1	
18	1UA-21651-00-GE	COVER, rear fender	1	UR SILKY WHITE
	1UA-21651-00-6G	COVER, rear fender	1	UR NEW YAMAHA BLACK
19	90480-19453	GROMMET	4	
20	1UA-21645-00	STAY, rear	1	
21	1J3-24742-00	GROMMET	2	
22	98006-08035	BOLT	4	

C12

FIG. 18 SIDE COVER

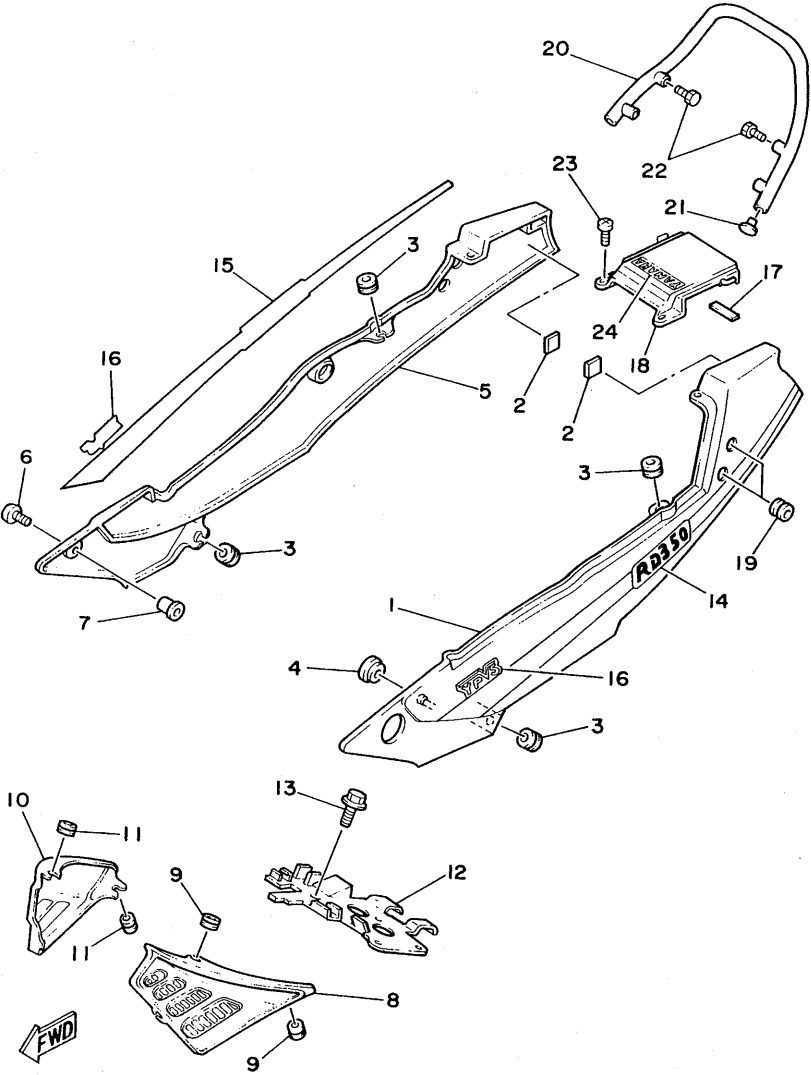

IUA300-6180

REF. NO.	PART NO.	DESCRIPTION	Q'TY	REMARKS
23	98906-06016	SCREW, bind	2	
24	1UA-2163G-00	EMBLEM 1	1	UR FOR SW
	1UA-2163G-10	EMBLEM 1	1	UR FOR NYB

C13

FIG. 19 OIL TANK

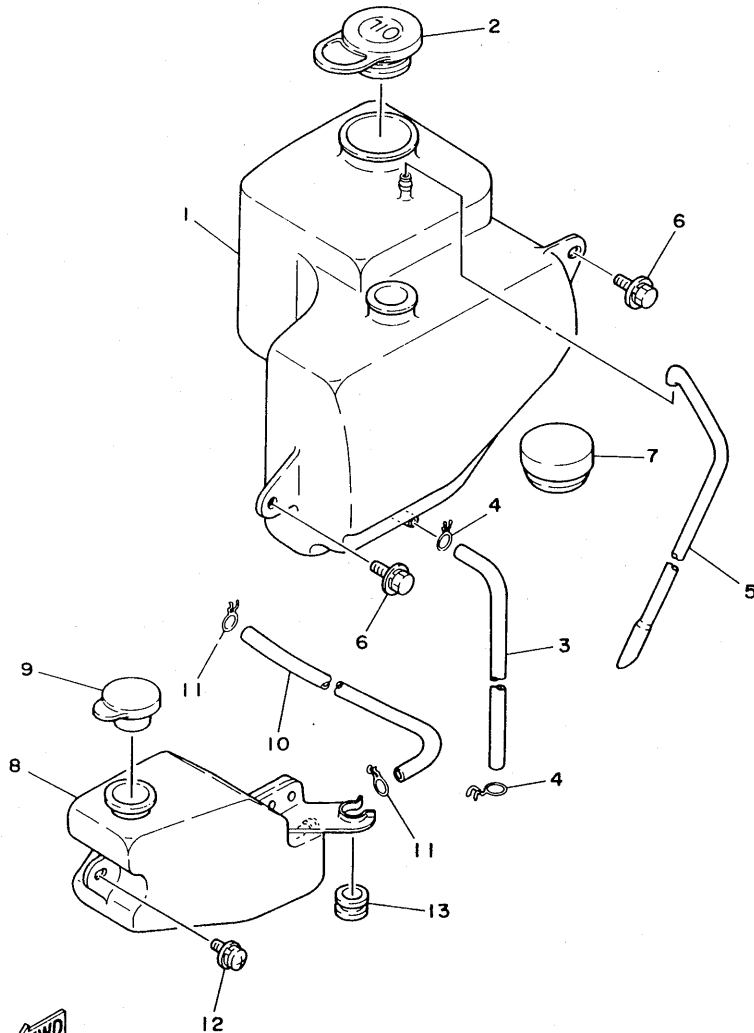

29L010-3210

REF. NO.	PART NO.	DESCRIPTION	Q'TY	REMARKS
1	29L-21751-01	TANK, oil	1	
2	10V-21771-00	BODY, cap	1	
3	29L-24316-00	PIPE 6	1	
4	90467-08003	CLIP	2	
5	29L-24317-00	PIPE 7	1	
6	90119-06044	BOLT, with washer	2	
7	29L-21746-00	DAMPER	1	
8	29L-21870-00	RECOVERY TANK ASSY	1	
9	4L0-21815-01	CAP	1	
10	29L-21766-00	PIPE, oil	1	
11	90467-10008	CLIP	2	
12	90159-06060	SCREW, with washer	1	
13	90480-12014	GROMMET	1	

C14

FIG. 20 REAR ARM

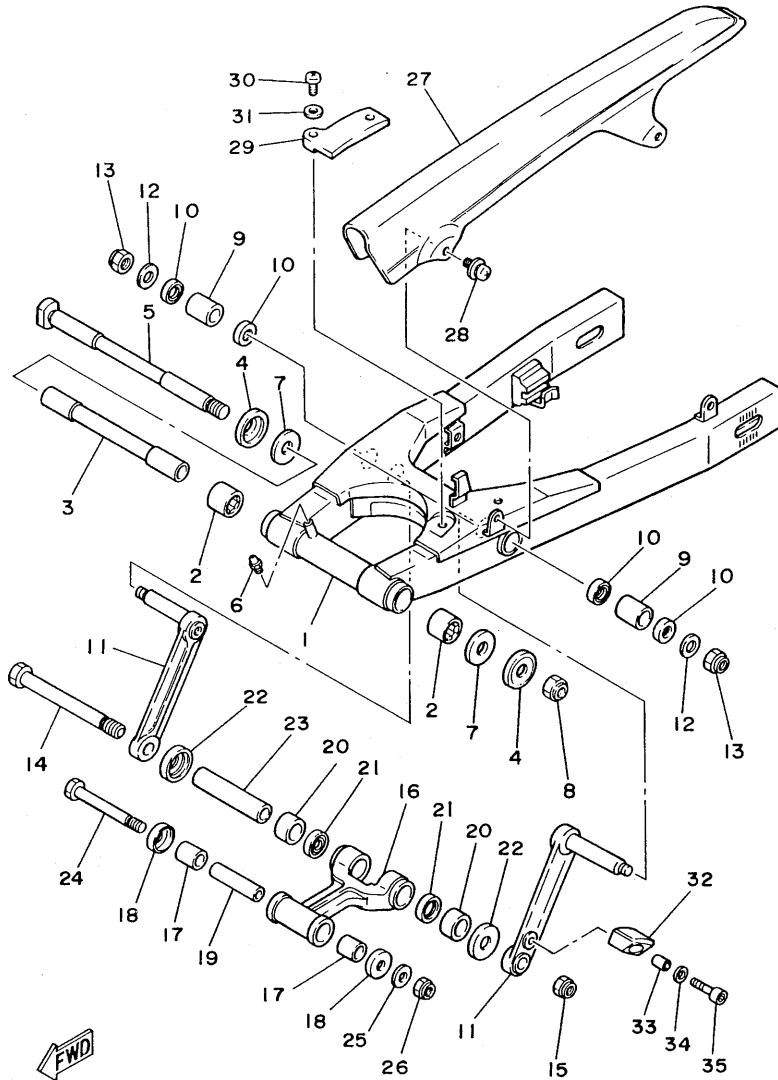

IWT310-6200

REF. NO.	PART NO.	DESCRIPTION	Q'TY	REMARKS
1	51L-22110-00-35	REAR ARM COMP.	1	SILVER
2	93320-32403	BEARING	2	
3	51L-22184-00	BUSH	1	
4	4X7-22129-00	COVER, thrust 2	2	
5	29L-22141-00	SHAFT, pivot	1	
6	93700-06004	NIPPLE, grease	1	
7	90201-161J3	WASHER, plate	2	
8	90185-14070	NUT, self-locking	1	
9	90386-18136	BUSH	2	
10	93109-18020	OIL SEAL	4	
11	31K-2217M-00	ARM 1	2	
12	90201-12191	WASHER, plate	2	
13	95601-12100	NUT, u	2	
14	90101-14654	BOLT	1	
15	90185-14137	NUT, self-locking	1	
16	31K-2217A-00	ARM, relay	1	
17	90386-18118	BUSH	2	
18	26H-22129-00	COVER, thrust 2	2	
19	90387-127H2	COLLAR	1	
20	90386-20134	BUSH	2	
21	93109-20029	OIL SEAL	2	
22	26H-22128-00	COVER, thrust 1	2	
23	90387-144H4	COLLAR	1	
24	90109-10739	BOLT	1	
25	90201-10126	WASHER, plate	1	
26	95602-10100	NUT, u	1	
27	29L-22311-00	CASE, chain	1	
28	90159-06084	SCREW, with washer	2	

C15

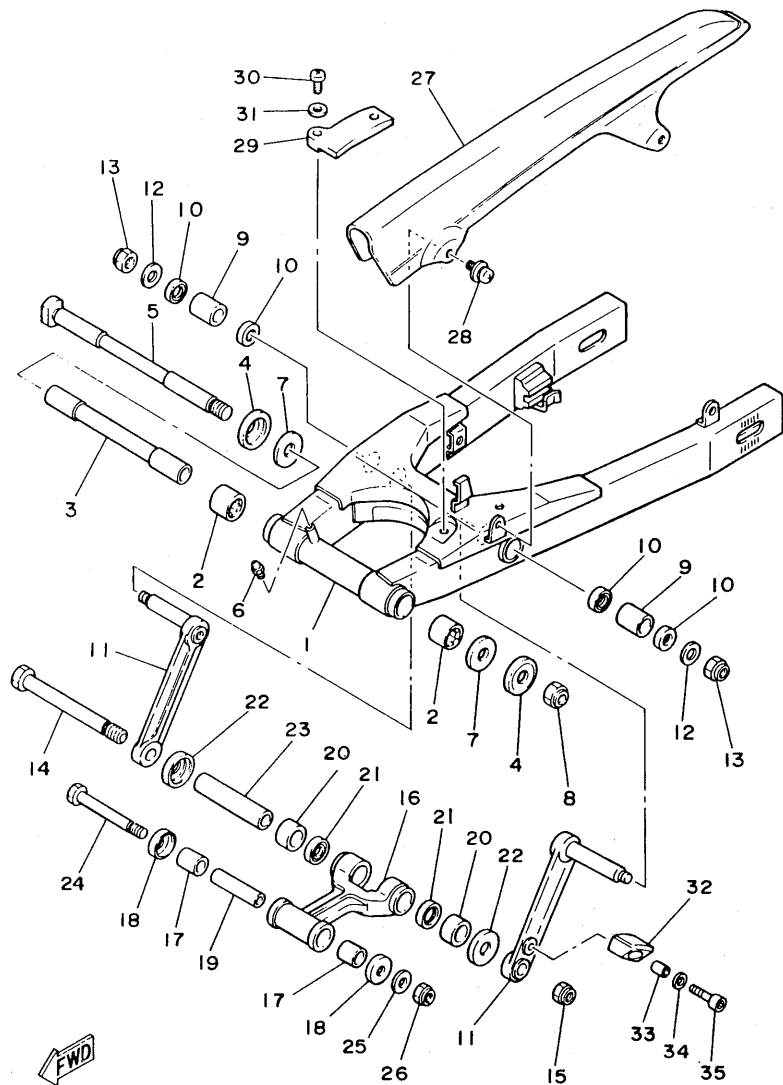

IWT310-6200

FIG. 20 REAR ARM

REF. NO.	PART NO.	DESCRIPTION	Q'TY	REMARKS
29	29L-22151-00	SEAL, guard	1	
30	98501-05010	SCREW, pan head	2	
31	92901-05600	WASHER, plate	2	
32	31K-22187-00	GUIDE, chain	1	
33	90387-060G5	COLLAR	1	
34	92901-06200	WASHER, plain	1	
35	91311-06030	BOLT	1	

D2

FIG. 21 REAR SUSPENSION

REF. NO.	PART NO.	DESCRIPTION	Q'TY	REMARKS
1	1UA-22210-00	SHOCK ABSORBER ASSY, rear	1	
2	29L-22216-00	.BUSH, rear shock absorber	1	
3	.BUSH, solid	2		
4	90387-106H5	COLLAR	1	
5	90109-10554	BOLT	1	
6	90201-10126	WASHER, plate	1	
7	95602-10100	NUT, u	1	
8	29L-2217H-00	COVER, dust	2	
9	90201-12729	WASHER, plate	1	

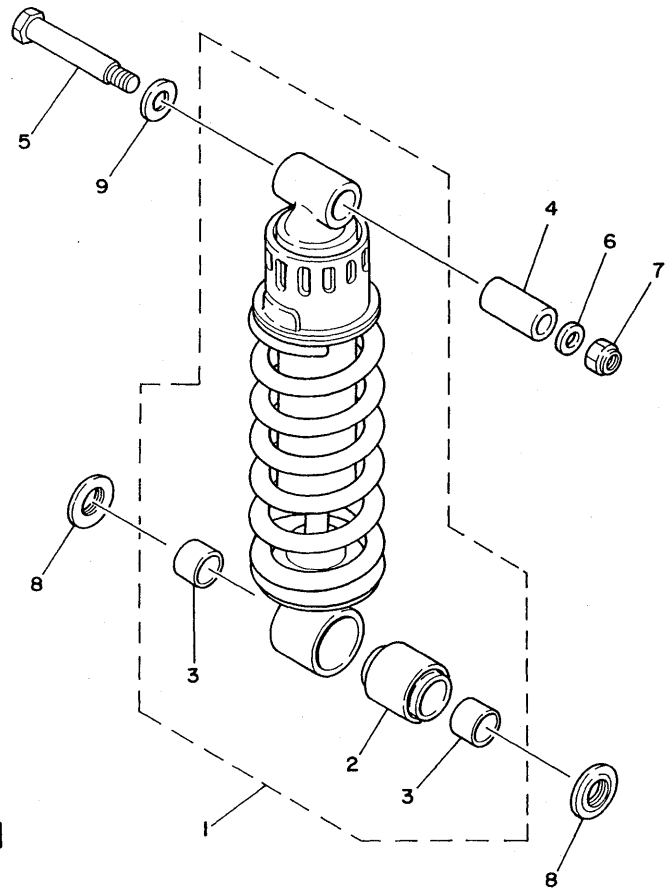

FWD

IWT310-6210

D3

FIG. 22 STEERING

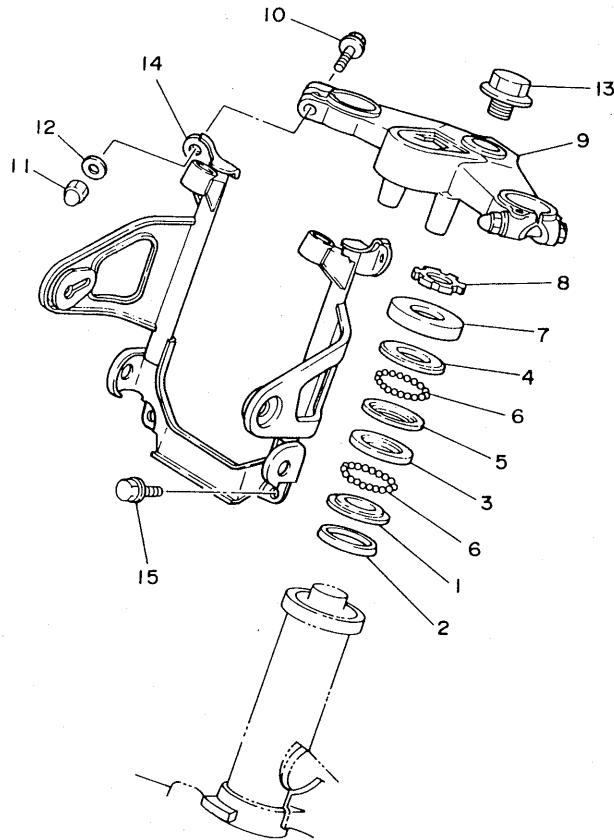

REF. NO.	PART NO.	DESCRIPTION	Q'TY	REMARKS
1	156-23411-00	RACE, ball 1	1	
2	164-23462-00	SEAL, steering	1	
3	156-23412-00	RACE, ball 2	1	
4	183-23411-00	RACE, ball 1	1	
5	183-23412-00	RACE, ball 2	1	
6	93501-04011	BALL	38	
7	4K0-23415-00	COVER, ball race 1	1	
8	90179-25495	NUT	1	
9	1UA-23435-00-98	CROWN, handle	1	LOW GLOSS BLACK
10	91026-08050	BOLT, flange	2	
11	95306-08800	NUT	2	
12	92906-08600	WASHER, plate	2	
13	90105-14365	BOLT, washer based	1	
14	1JF-23174-00	STAY, headlight	1	
15	95026-08030	BOLT, flange	2	



IUA300-6220

D4

FIG. 23 FRONT FORK

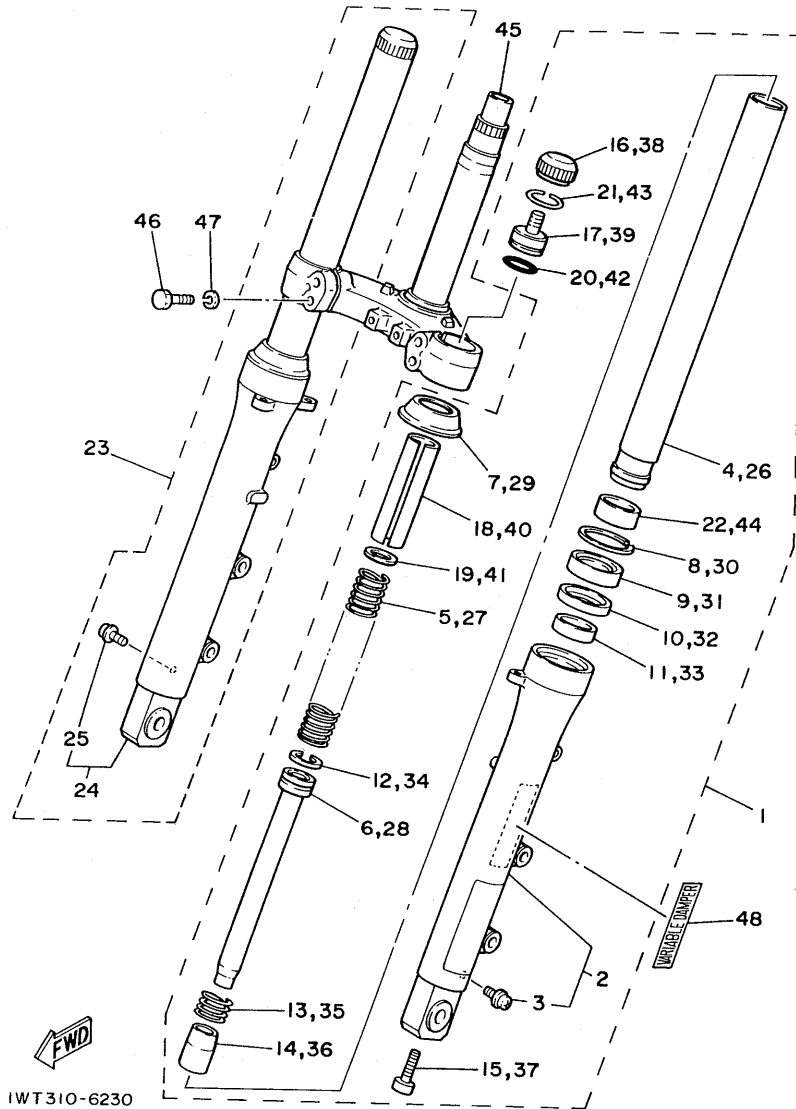

IWT310-6230

REF. NO.	PART NO.	DESCRIPTION	Q'TY	REMARKS
1	1UA-23102-00	FRONT FORK ASSY (L.H)	1	
2	51L-23126-00-38	.TUBE, outer 1	1	CLEAR BUFFING
3	1E7-23119-00	..PLUG, drain	1	
4	1UA-23110-00	.INNER TUBE COMP.1	1	
5	1UA-23141-00	.SPRING, front fork	1	
6	1UA-23171-00	.PISTON, front fork	1	
7	1UA-23144-00	.SEAL, dust	1	
8	34X-23156-00	.CLIP, oil seal	1	
9	1UA-23145-00	.OIL SEAL	1	
10	10V-23147-00	.O-RING	1	
11	51L-23125-00	.METAL, slide 1	1	
12	51L-23157-00	.RING, piston	1	
13	51L-23151-00	.SPRING, rebound	1	
14	10V-23166-00	.SPACER, oil lock	1	
15	3M7-23181-00	.BOLT, hexagon socket head	1	
16	1UA-23168-00	.CAP, front fork	1	
17	1UA-23111-00	.BOLT, cap	1	
18	51L-23118-00	.SPACER	1	
19	51L-23142-00	.SEAT, spring upper	1	
20	1UA-23147-00	.O-RING	1	
21	1UA-23153-00	.RING, snap	1	
22	10V-23135-00	.METAL, slide 2	1	
23	1UA-23103-00	FRONT FORK ASSY (R.H)	1	
24	51L-23136-00-38	.TUBE, outer 2	1	CLEAR BUFFING
25	1E7-23119-00	..PLUG, drain	1	
26	1UA-23110-00	.INNER TUBE COMP.1	1	
27	1UA-23141-00	.SPRING, front fork	1	
28	1UA-23171-00	.PISTON, front fork	1	

D5

FIG. 23 FRONT FORK

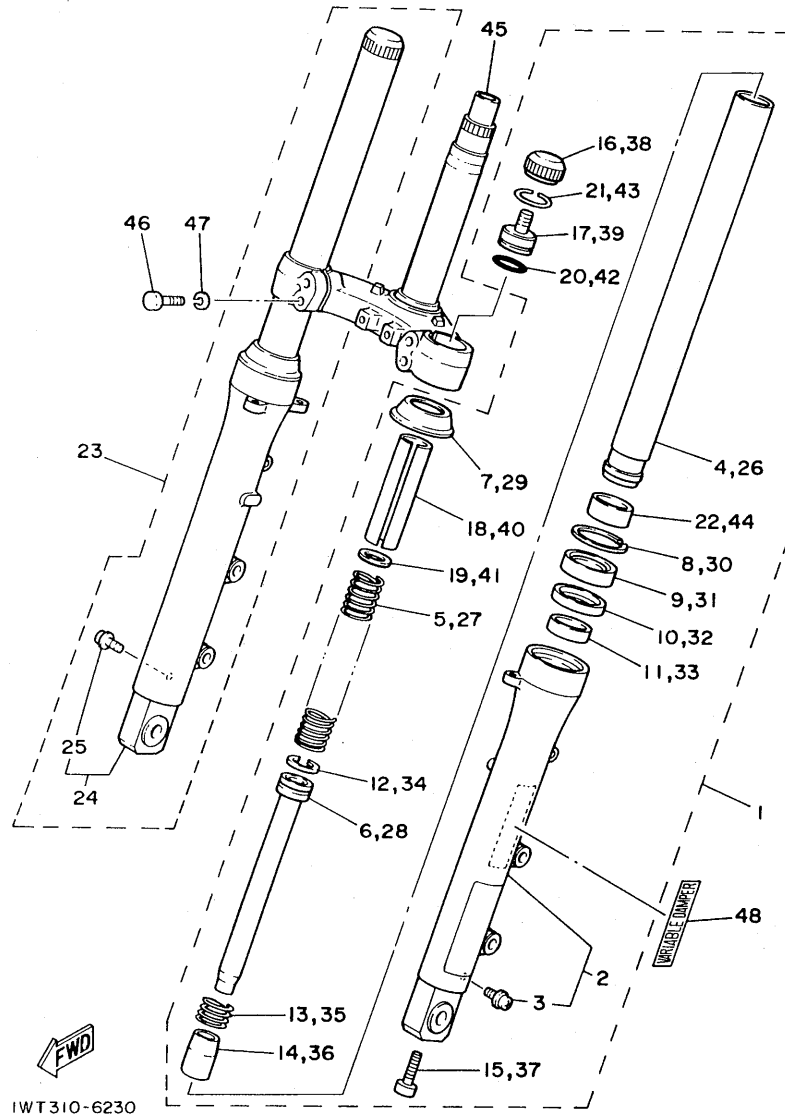

IWT310-6230

REF. NO.	PART NO.	DESCRIPTION	Q'TY	REMARKS
29	1UA-23144-00	.SEAL, dust	1	
30	34X-23156-00	.CLIP, oil seal	1	
31	1UA-23145-00	.OIL SEAL	1	
32	10V-23147-00	.O-RING	1	
33	51L-23125-00	.METAL, slide 1	1	
34	51L-23157-00	.RING, piston	1	
35	51L-23151-00	.SPRING, rebound	1	
36	10V-23166-00	.SPACER, oil lock	1	
37	3M7-23181-00	.BOLT, hexagon socket head	1	
38	1UA-23168-00	.CAP, front fork	1	
39	1UA-23111-00	.BOLT, cap	1	
40	51L-23118-00	.SPACER	1	
41	51L-23142-00	.SEAT, spring upper	1	
42	1UA-23147-00	.O-RING	1	
43	1UA-23153-00	.RING, snap	1	
44	10V-23135-00	.METAL, slide 2	1	
45	31K-23340-30	UNDER BRACKET COMP.	1	
46	90101-08592	BOLT	2	
47	3J3-23159-00	WASHER, spring, lower	2	
48	51L-23108-00	EMBLEM	2	

D6

FIG. 24 FUEL TANK

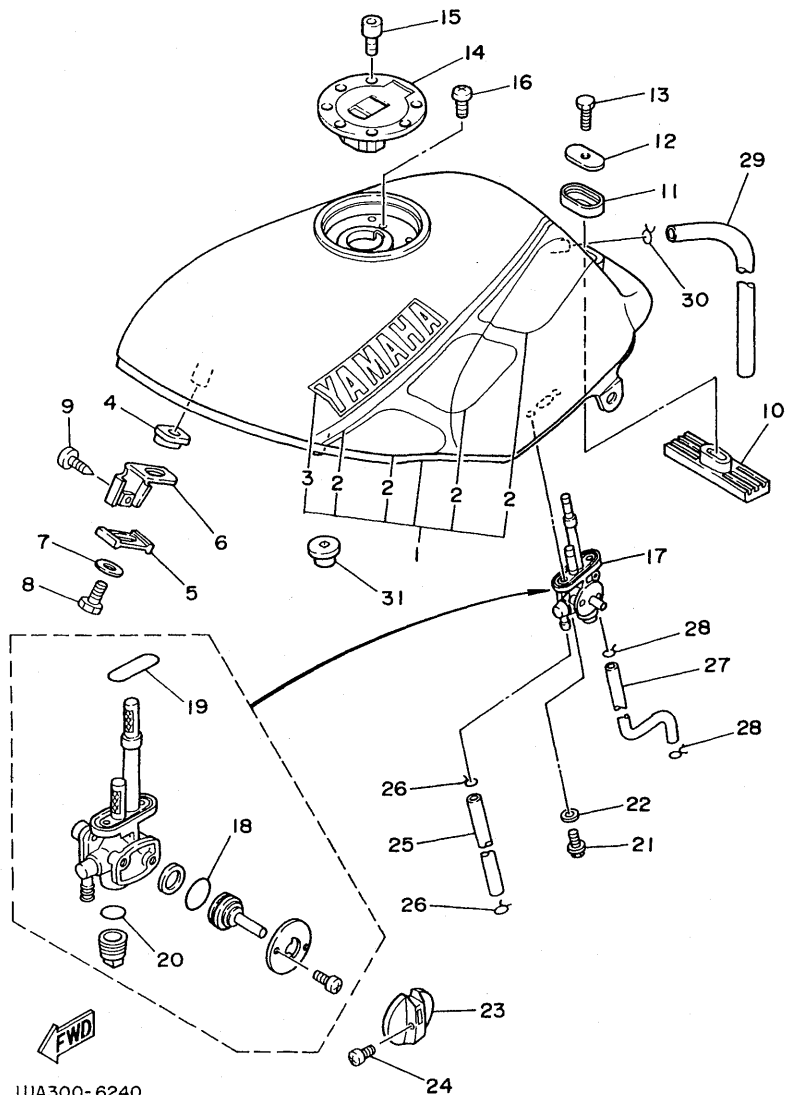

1UA300-6240

REF. NO.	PART NO.	DESCRIPTION	Q'TY	REMARKS
1	1UA-24110-00-04	FUEL TANK COMP.	1	UR SILKY WHITE
	1UA-24110-00-05	FUEL TANK COMP.	1	UR NEW YAMAHA BLACK
2	1UA-24240-00	.GRAPHIC SET	1	UR FOR SW
	1UA-24240-10	.GRAPHIC SET	1	UR FOR NYB
3	1UA-24161-00	.EMBLEM 1	2	UR FOR SW
	1WT-24161-00	.EMBLEM 1	2	UR FOR NYB
4	1A0-24181-00	DAMPER, locating 1	2	
5	1A0-24186-00	WASHER, special	2	
6	1UA-24191-00	BRACKET, fuel tank 1	2	
7	90209-06186	WASHER	2	
8	98006-06008	BOLT	2	
9	90157-06046	SCREW, pan head	2	
10	29L-24182-00	DAMPER, locating 2	1	
11	3Y6-24183-00	DAMPER, locating 3	1	
12	12R-24186-00	WASHER, special	1	
13	98002-08030	BOLT	1	
14	1TV-24602-00	CAP ASSY	1	
15	90110-05112	BOLT, hexagon socket head	3	
16	98501-05010	SCREW, pan head	1	
17	1UA-24500-00	FUEL COCK ASSY 1	1	
18	3H3-24534-00	.O-RING	1	
19	2W6-24512-00	.O-RING	1	
20	4X8-24565-00	.GASKET	1	
21	90149-06011	SCREW	2	
22	90202-06010	WASHER, plate	2	
23	46X-24524-00	LEVER, cock	1	
24	98506-03008	SCREW, pan head	1	
25	1UA-24311-00	PIPE, fuel 1	1	

D7

FIG. 24 FUEL TANK

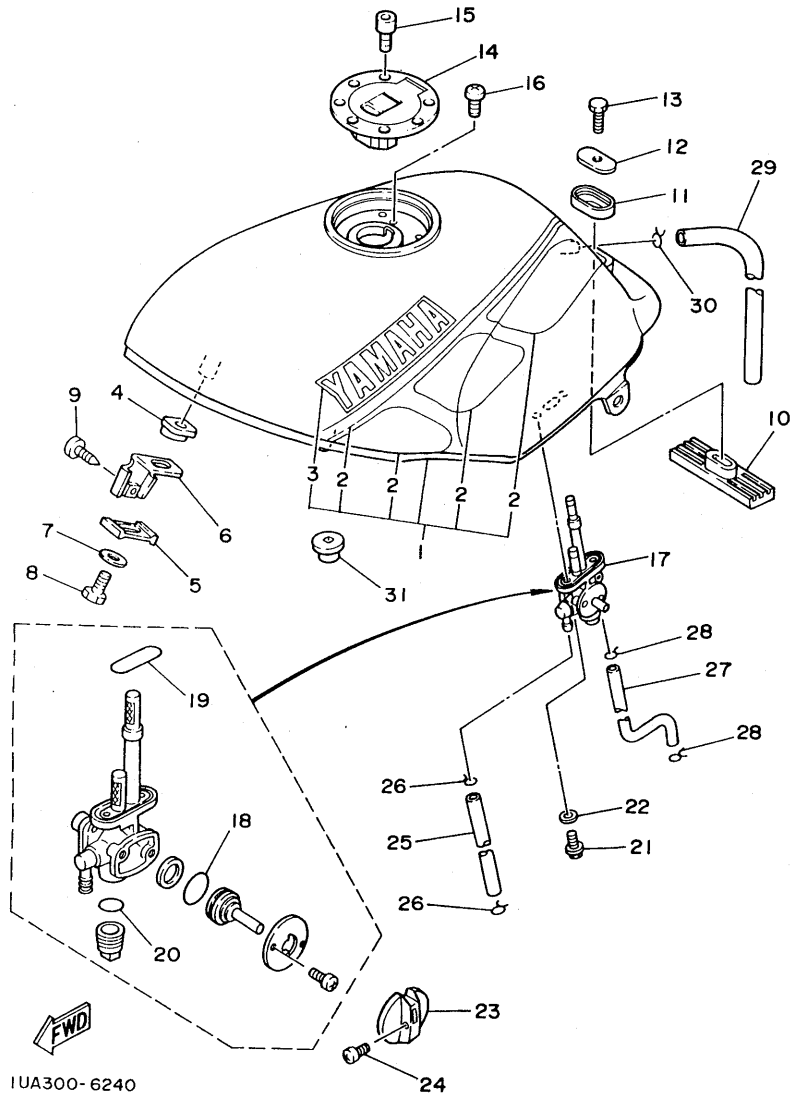

IUA300-6240

REF. NO.	PART NO.	DESCRIPTION	Q'TY	REMARKS
26	90467-10041	CLIP	2	
27	29L-2416A-00	HOSE	1	
28	90467-08075	CLIP	2	
29	1JK-24315-00	PIPE 5	1	
30	90467-09006	CLIP	1	

D8

FIG. 25 SEAT

REF. NO.	PART NO.	DESCRIPTION	Q'TY	REMARKS
1	1UA-24730-00	DOUBLE SEAT ASSY	1	UR BLACK
	1UA-24730-20	DOUBLE SEAT ASSY	1	UR RED
2	1UA-24731-00	.COVER, seat	1	UR BLACK
	1UA-24731-20	.COVER, seat	1	UR RED
3	41Y-24705-01	SEAT LOCK ASSY	1	
4	92502-06016	SCREW, pan head	2	
5	92990-06100	WASHER, spring	2	
6	31A-24760-00	SEAT LEVER ASSY	1	
7	92502-06016	SCREW, pan head	2	
8	92990-06100	WASHER, spring	2	

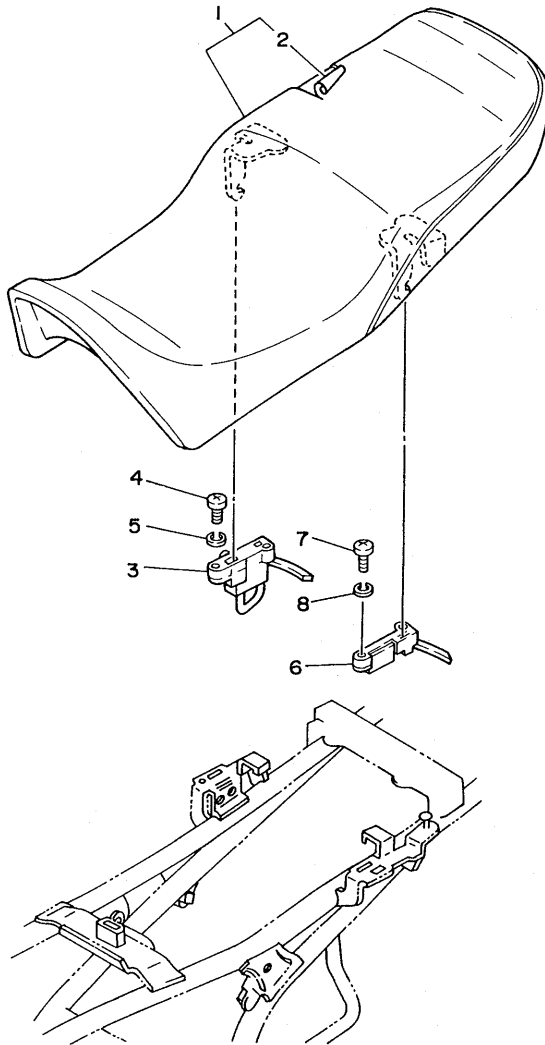

IWT310-6250

D9

FIG. 26 FRONT WHEEL

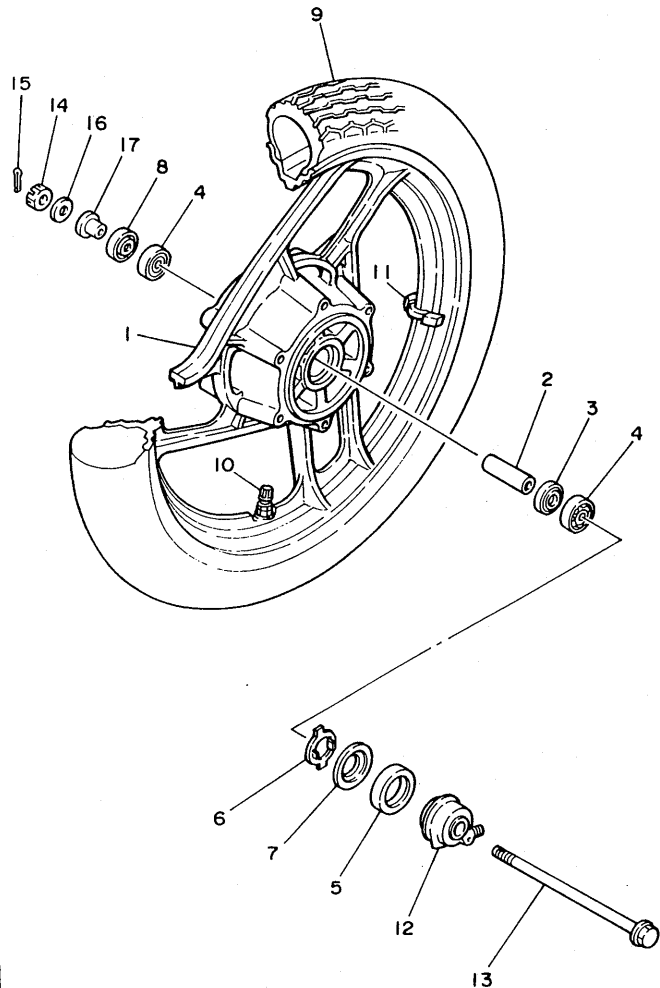

REF. NO.	PART NO.	DESCRIPTION	Q'TY	REMARKS
1	1UA-25168-00-FH	CAST WHEEL, front	1	FIRE RED
2	90387-123A9	COLLAR	1	
3	2U2-25315-00	FLANGE, spacer	1	
4	93306-30109	BEARING	2	
5	93105-45017	OIL SEAL	1	
6	341-25149-00	CLUTCH, meter	1	
7	341-25846-00	RETAINER, clutch	1	
8	93106-20002	OIL SEAL	1	
9	94109-187J7	TIRE (90/90 51H F202)	1	UR YOKOHAMA
	94109-184J2	TIRE (90/90 51H K300M)	1	UR DUNLOP
10	93900-00018	VALVE, rim	1	UR YOKOHAMA
	93900-00015	VALVE, rim	1	UR DUNLOP
11	29L-25398-00	BALANCER, wheel (10G)	1	UN
	29L-25398-10	BALANCER, wheel (20G)	1	UN
	29L-25398-20	BALANCER, wheel (30G)	1	UN
12	4L0-25190-00	GEAR UNIT ASSY	1	
13	4L0-25181-00	AXLE, wheel	1	
14	90171-12005	NUT, castle	1	
15	91401-30025	PIN, cotter	1	
16	92901-12200	WASHER, plain	1	
17	90387-12670	COLLAR	1	



IWT310-6260

D10

FIG. 27 FRONT BRAKE CALIPER

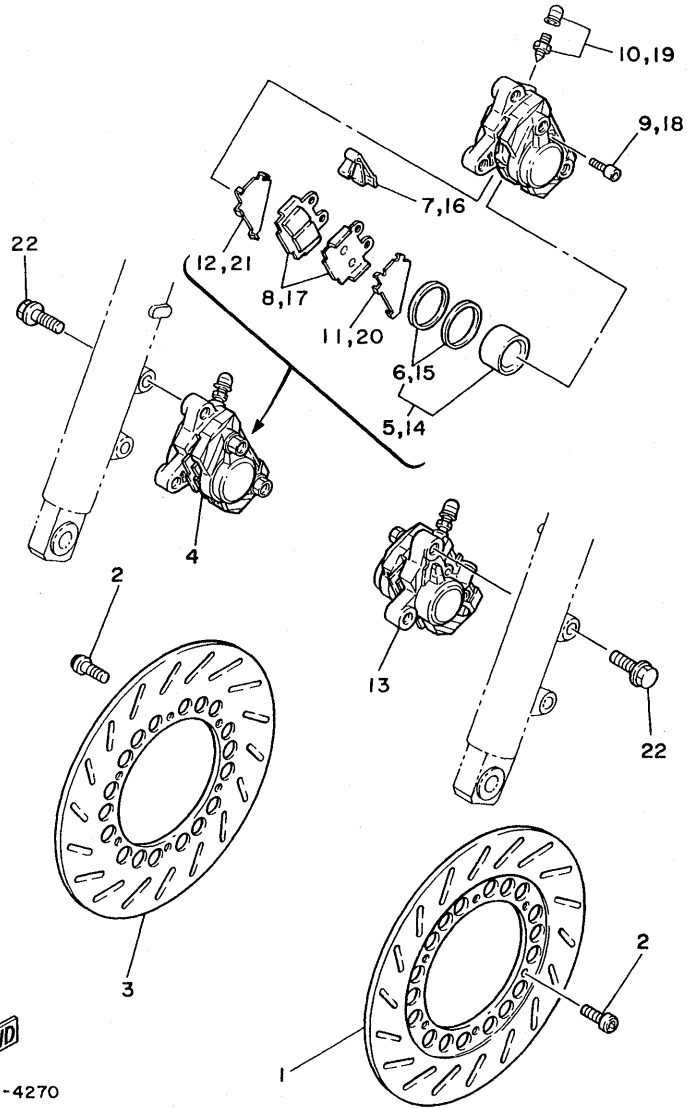

IAR010-4270

REF. NO.	PART NO.	DESCRIPTION	Q'TY	REMARKS
1	1UA-25831-10-33	DISC, brake (LEFT)	1	YAMAHA BLACK
2	90149-08230	SCREW	12	
3	1UA-25831-00-33	DISC, brake (RIGHT)	1	YAMAHA BLACK
4	51L-25810-00	CALIPER ASSY (RIGHT)	1	
5	51L-W0057-00	.PISTON ASSY, caliper	1	
6	51L-W0047-00	..CALIPER SEAL KIT	1	
7	51L-25919-00	.SUPPORT, pad	1	
8	51L-W0046-00	.BRAKE PAD KIT, rear	1	
9	51L-25924-00	.PIN, pad	2	
10	51L-W0048-00	.BREED SCREW KIT	1	
11	51L-25827-00	.SHIM, caliper	1	
12	51L-25827-10	.SHIM, caliper	1	
13	51L-25810-10	CALIPER ASSY (LEFT)	1	
14	51L-W0057-00	.PISTON ASSY, caliper	1	
15	51L-W0047-00	..CALIPER SEAL KIT	1	
16	51L-25919-00	.SUPPORT, pad	1	
17	51L-W0046-00	.BRAKE PAD KIT, rear	1	
18	51L-25924-00	.PIN, pad	2	
19	51L-W0048-00	.BREED SCREW KIT	1	
20	51L-25827-00	.SHIM, caliper	1	
21	51L-25827-10	.SHIM, caliper	1	
22	90105-10308	BOLT, washer based	4	

D11

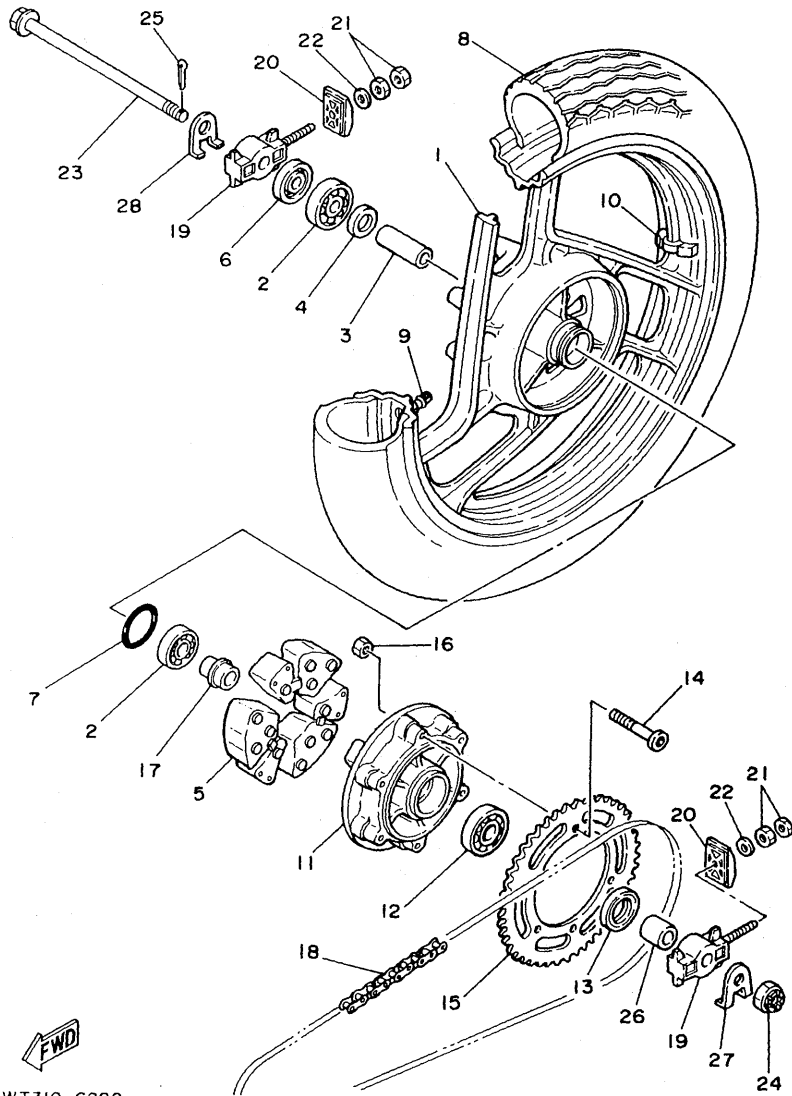

IWT310-6280

FIG. 28 REAR WHEEL

REF. NO.	PART NO.	DESCRIPTION	Q'TY	REMARKS
1	1UA-25338-20-FH	CAST WHEEL, rear	1	FIRE RED
2	93306-30206	BEARING (B6302ZZ)	2	
3	90387-154A0	COLLAR	1	
4	2R6-25115-00	FLANGE, spacer 1	1	
5	29L-25364-00	DAMPER	3	
6	93102-22014	OIL SEAL	1	
7	93210-48530	O-RING	1	
8	94111-187M4	TIRE (110/80-18 58H R-202)	1	UR YOKOHAMA
	94111-184J3	TIRE (110/80-18 58H K300)	1	UR DUNLOP
9	93900-00018	VALVE, rim	1	UR YOKOHAMA
	93900-00015	VALVE, rim	1	UR DUNLOP
10	29L-25398-00	BALANCER, wheel (10G)	1	UN
	29L-25398-10	BALANCER, wheel (20G)	1	UN
	29L-25398-20	BALANCER, wheel (30G)	1	UN
11	29L-25366-00	CLUTCH, hub	1	
12	93306-30416	BEARING (B6304RS)	1	
13	93102-32298	OIL SEAL	1	
14	90110-08057	BOLT, hexagon socket head	6	
15	31K-25439-20-33	SPROCKET, driven (39T)	1	YAMAHA BLACK
16	90185-08113	NUT, self-locking	6	
17	4L0-25377-00	COLLAR, wheel	1	
18	94580-93106	CHAIN	1	
19	51L-25388-00	PULLER, chain 1	2	
20	51L-22174-00	END 1	2	
21	95301-08600	NUT	4	
22	92901-08600	WASHER, plate	2	
23	51L-25381-01	AXLE, wheel	1	
24	90171-14020	NUT, castle	1	

D12

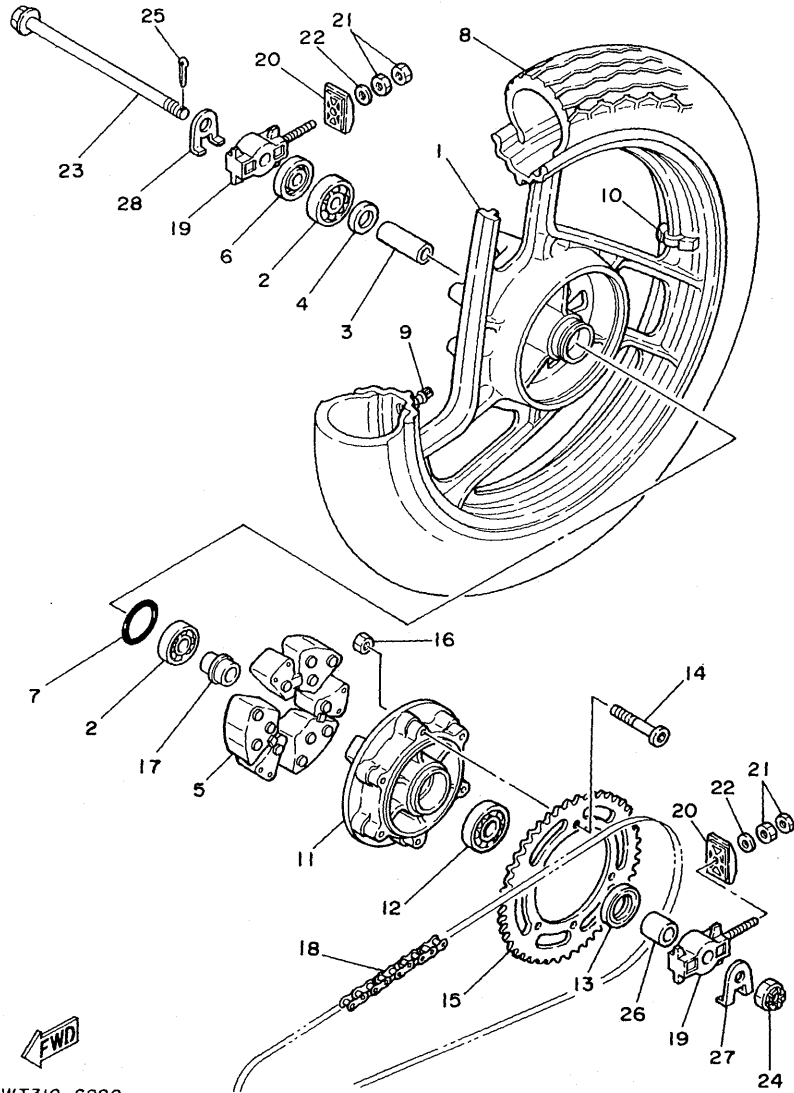

FIG. 28 REAR WHEEL

REF. NO.	PART NO.	DESCRIPTION	Q'TY	REMARKS
25	91401-30030	PIN, cotter	1	
26	90387-156L5	COLLAR	1	
27	51L-2533A-00	PLATE, indicator	1	
28	51L-2533E-00	PLATE, indicator 2	1	

IWT310-6280

D13

FIG. 29 REAR BRAKE CALIPER

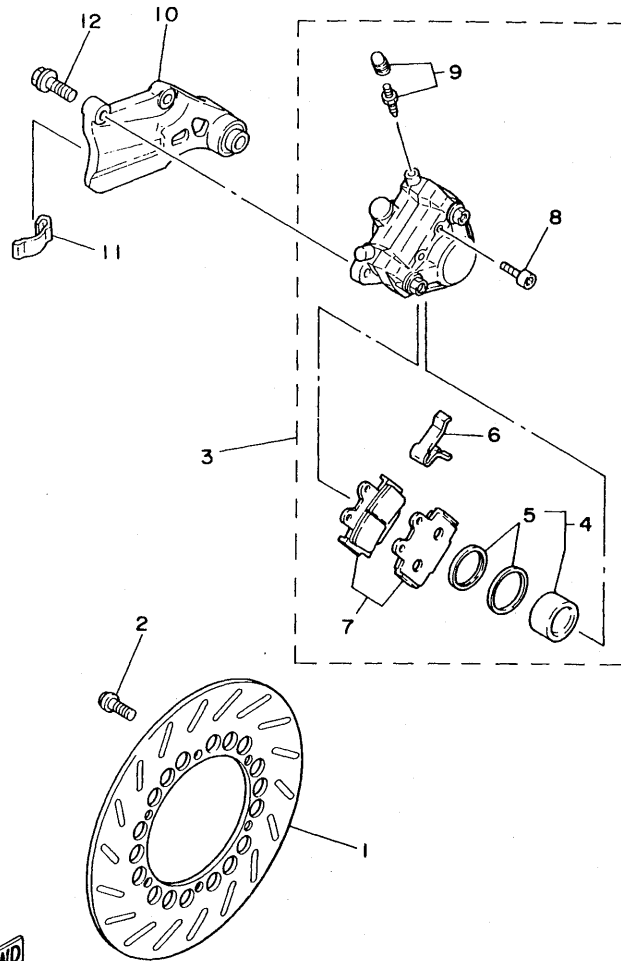

REF. NO.	PART NO.	DESCRIPTION	Q'TY	REMARKS
1	1UA-25831-00-33	DISC, brake (RIGHT)	1	YAMAHA BLACK
2	90149-08230	SCREW	6	
3	51L-25810-50	CALIPER ASSY	1	
4	51L-W0057-00	.PISTON ASSY, caliper	1	
5	51L-W0047-00	..CALIPER SEAL KIT	1	
6	51L-25919-00	.SUPPORT, pad	1	
7	51L-W0046-00	.BRAKE PAD KIT, rear	1	
8	51L-25924-00	.PIN, pad	2	
9	51L-W0048-00	.BREED SCREW KIT	1	
10	51L-25819-00-98	BRACKET, caliper	1	LOW GLOSS BLACK
11	33M-25927-00	SPRING, support	1	
12	90105-10363	BOLT, washer based	2	

51LO10-4290

D14

FIG. 30 STEERING HANDLE. CABLE

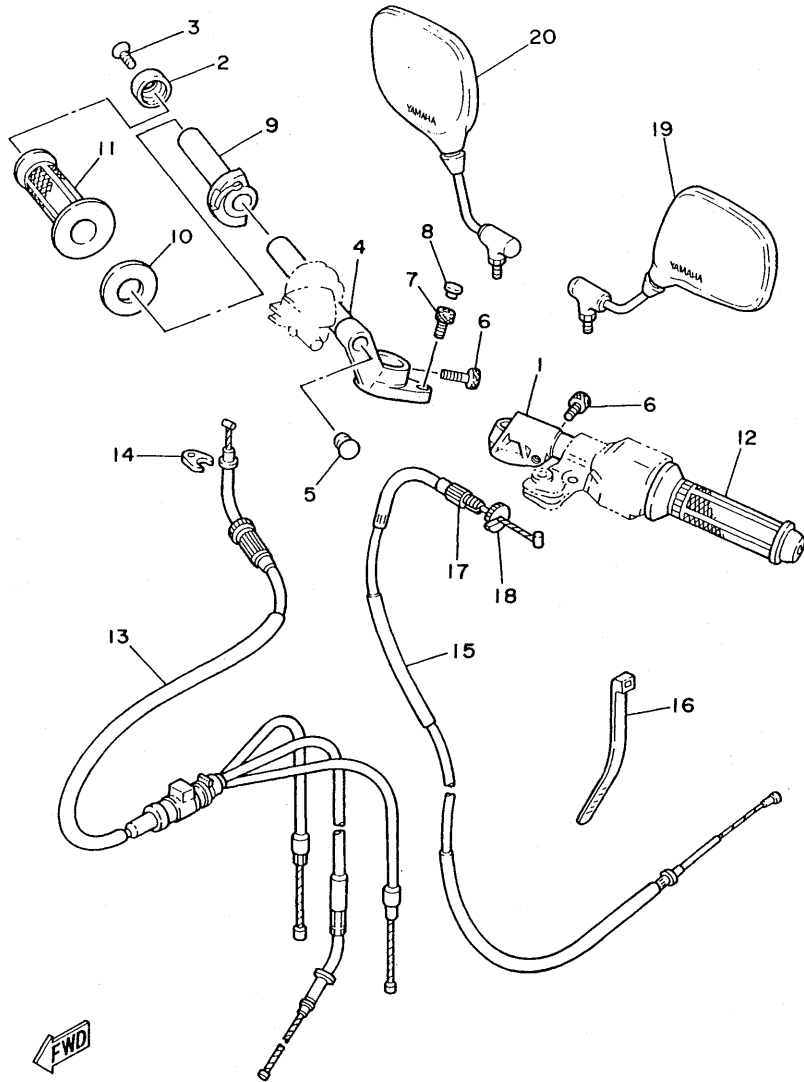

IUA300-6300

REF. NO.	PART NO.	DESCRIPTION	Q'TY	REMARKS
1	1JF-26121-00	HANDLEBAR (LEFT)	1	
2	29L-26246-00	END, grip	2	
3	92706-06030	SCREW, flat head	2	
4	1JF-26122-00	HANDLEBAR (RIGHT)	1	
5	90338-19166	PLUG	2	
6	91316-08025	BOLT	2	
7	91316-06016	BOLT	2	
8	2H9-23469-00	CAP, bolt	2	
9	36Y-26243-00	TUBE, throttle guide	1	
10	2H7-26249-00	RING, leaf	1	
11	31A-26242-00	GRIP (R.H)	1	
12	31A-26241-00	GRIP (L.H)	1	
13	1UA-26260-00	CABLE ASSY, throttle & pump	1	
14	5H0-26393-00	HOLDER	1	
15	1UA-26335-00	CABLE, clutch	1	
16	5A8-82591-00	BAND	1	
17	90123-08083	BOLT	1	
18	90179-08316	NUT	1	
19	1UA-26280-00	BACK MIRROR ASSY (LEFT)	1	
20	1UA-26290-00	BACK MIRROR ASSY (RIGHT)	1	

D15

FIG. 31 FRONT MASTER CYLINDER

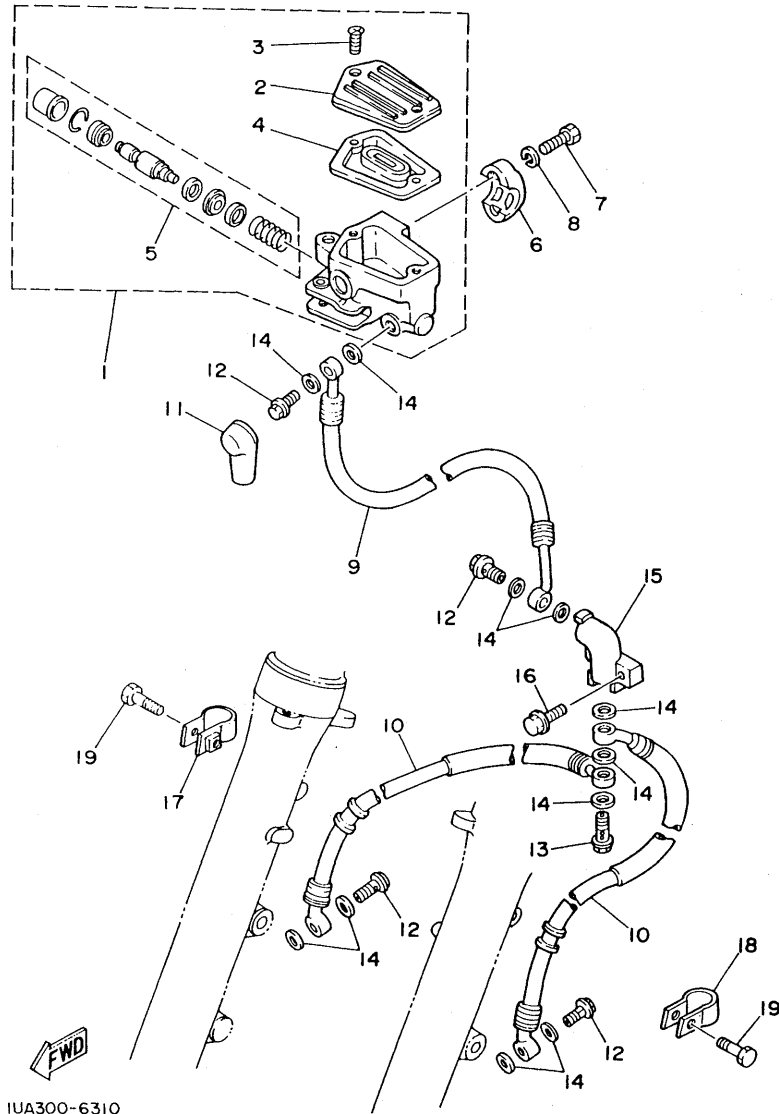

IUA300-6310

REF. NO.	PART NO.	DESCRIPTION	Q'TY	REMARKS
1	36Y-25850-00	MASTER CYLINDER ASSY	1	
2	1AE-25852-00	.CAP, reservoir	1	
3	98706-04012	.SCREW, flat head	2	
4	36Y-25854-00	.DIAPHRAGM, reservoir	1	
5	36Y-W0041-00	.CYLINDER KIT, master	1	
6	36Y-25867-00	BRACKET, master cylinder	1	
7	91316-06025	BOLT	2	
8	92906-06100	WASHER, spring	2	
9	57V-25872-00	HOSE, brake 1	1	
10	51L-25873-00	HOSE, brake 2	2	
11	4L0-25862-00	BOOT, master cylinder	1	
12	90401-10096	BOLT, union	4	
13	90401-10095	BOLT, union	1	
14	90201-10118	WASHER, plate	11	
15	47X-25885-00	JOINT	1	
16	98006-06025	BOLT	1	
17	4L0-25875-00	HOLDER, brake hose 1	1	
18	2R8-25876-00	HOLDER, brake hose 2	1	
19	97001-06025	BOLT	2	

E2

FIG. 32 STAND. FOOTREST

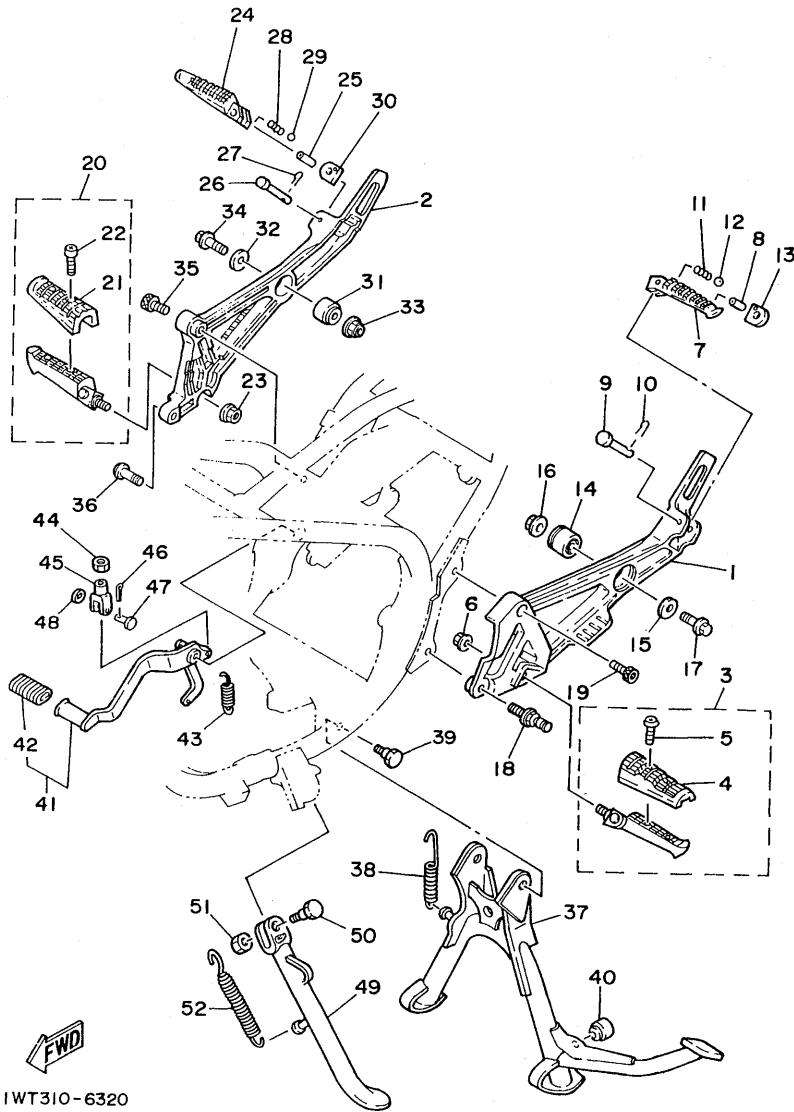

IWT310-6320

REF. NO.	PART NO.	DESCRIPTION	Q'TY	REMARKS
1	1UA-27442-00	BRACKET 2	1	
2	1UA-27443-00	BRACKET 3	1	
3	1UA-27410-00	FRONT FOOTREST ASSY (LEFT)	1	
4	46X-27413-00	.COVER, footrest	1	
5	90157-05079	.SCREW, pan head	2	
6	90185-10115	NUT, self-locking	1	
7	1HX-27431-00	FOOTREST, rear 1	1	
8	90387-064H8	COLLAR	1	
9	91701-06045	PIN, clevis	1	
10	91401-20015	PIN, cotter	1	
11	90501-12743	SPRING, compression	1	
12	93501-04004	BALL	1	
13	1HX-27437-00	WASHER, special	1	
14	29L-27414-01	DAMPER, footrest	1	
15	90209-08249	WASHER	1	
16	90185-08097	NUT, self-locking	1	
17	90105-08284	BOLT, washer based	1	
18	90109-10754	BOLT	1	
19	91316-10030	BOLT	1	
20	1UA-27420-00	FRONT FOOTREST ASSY (RIGHT)	1	
21	46X-27413-00	.COVER, footrest	1	
22	90157-05079	.SCREW, pan head	2	
23	90185-10115	NUT, self-locking	1	
24	1HX-27441-00	FOOTREST, rear 2	1	
25	90387-064H8	COLLAR	1	
26	91701-06045	PIN, clevis	1	
27	91401-20015	PIN, cotter	1	
28	90501-12743	SPRING, compression	1	

E3

FIG. 32 STAND, FOOTREST

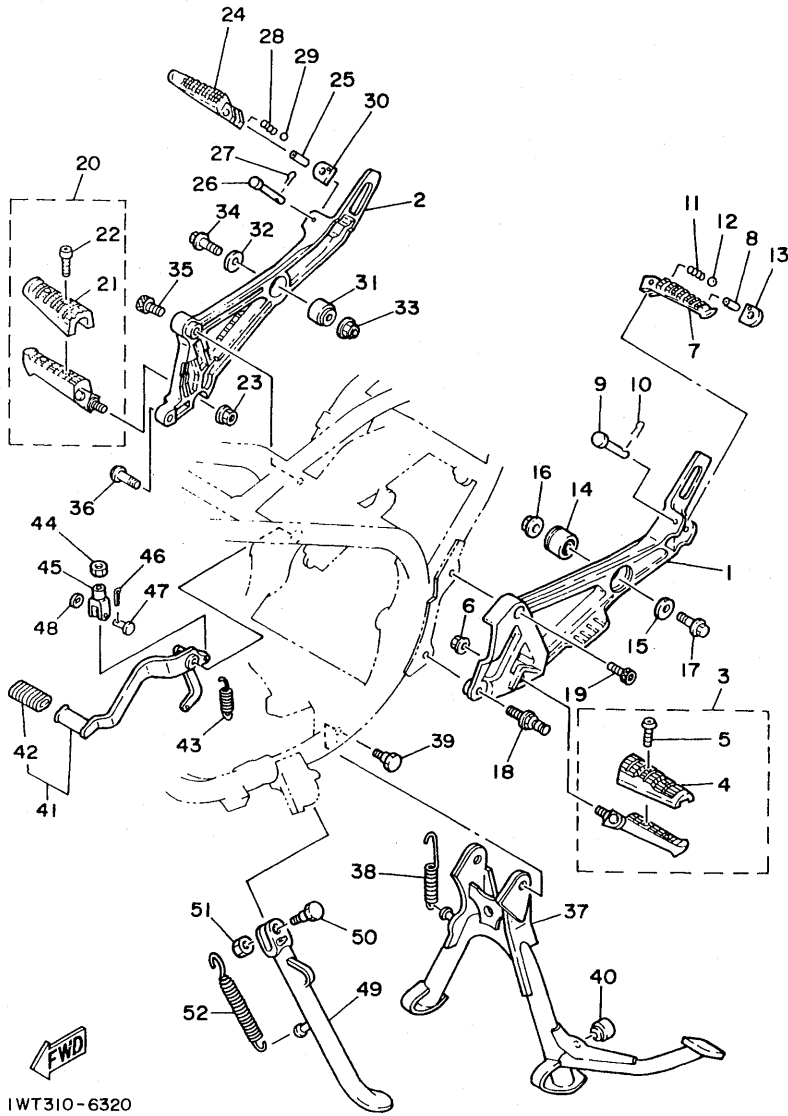

IWT310-6320

REF. NO.	PART NO.	DESCRIPTION	Q'TY	REMARKS
29	93501-04004	BALL	1	
30	1HX-27437-00	WASHER, special	1	
31	29L-27414-01	DAMPER, footrest	1	
32	90209-08249	WASHER	1	
33	90185-08097	NUT, self-locking	1	
34	90105-08284	BOLT, washer based	1	
35	91316-10030	BOLT	1	
36	90149-10232	SCREW	1	
37	29L-27111-01-33	STAND, main	1	YAMAHA BLACK
38	90506-35349	SPRING, tension	1	
39	90109-10737	BOLT	2	
40	909-27114-00	STOPPER, main stand	1	
41	51L-27200-00	PEDAL, brake	1	
42	22N-18113-00	COVER, shift pedal	1	
43	90506-20192	SPRING, tension	1	
44	95301-08700	NUT	1	
45	1J3-27222-01	JOINT	1	
46	91401-16012	PIN, cotter	1	
47	90240-08013	PIN, clevis	1	
48	90201-08083	WASHER, plate	1	
49	29L-27311-00-33	STAND, side	1	YAMAHA BLACK
50	90109-10590	BOLT	1	
51	90185-10037	NUT, self-locking	1	
52	90507-29032	SPRING, tension	1	

E4

FIG. 33 REAR MASTER CYLINDER

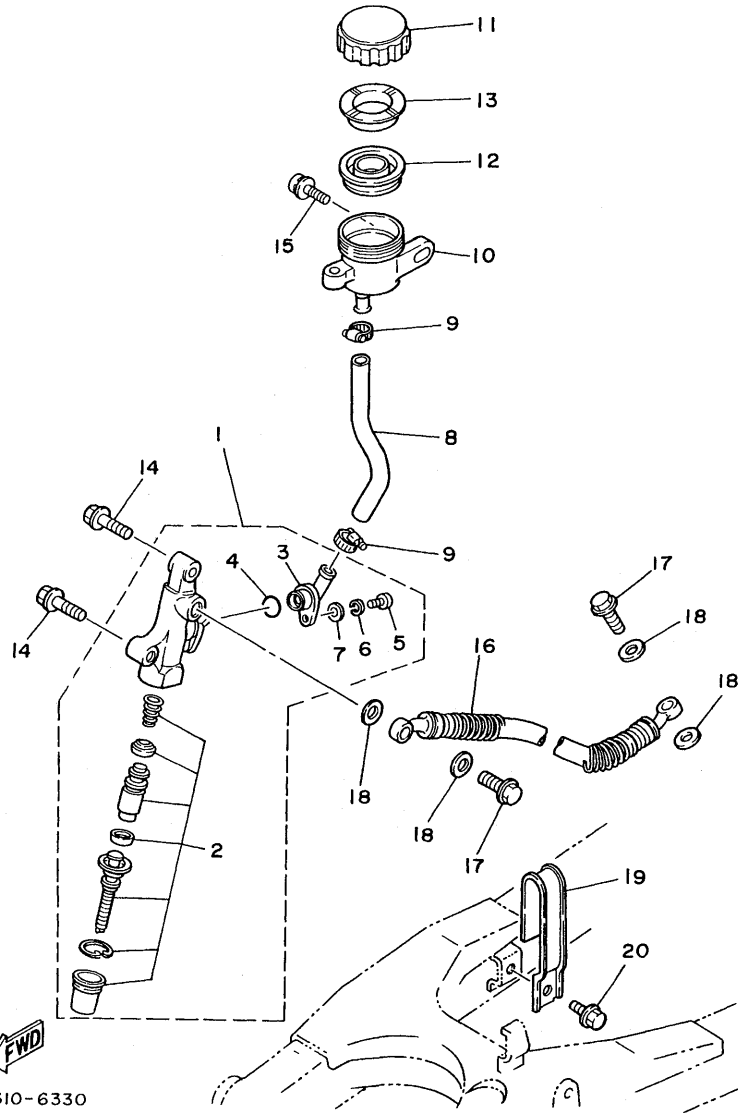

REF. NO.	PART NO.	DESCRIPTION	Q'TY	REMARKS
1	29L-25850-51	MASTER CYLINDER ASSY	1	
2	29L-W0042-50	.CYLINDER KIT, master	1	
3	29L-2582A-50	.JOINT	1	
4	93210-15620	.O-RING	1	
5	98511-04012	.SCREW, pan head	1	
6	92902-04100	.WASHER, spring	1	
7	92901-04600	.WASHER, plate	1	
8	29L-25895-00	HOSE, reservoir	1	
9	90467-14057	CLIP	2	
10	1A1-25894-01	TANK, reservoir	1	
11	1A1-25852-00	CAP, reservoir	1	
12	360-25854-00	DIAPHRAGM, reservoir	1	
13	360-25855-01	BUSH,diaphragm	1	
14	90157-08066	SCREW, pan head	2	
15	90159-06056	SCREW, with washer	1	
16	51L-25872-50	HOSE, brake l	1	
17	90401-10096	BOLT, union	2	
18	90201-10118	WASHER, plate	4	
19	29L-25875-00	HOLDER, brake hose l	1	
20	98006-06010	BOLT	1	

IWT310-6330

E5

FIG. 34 GENERATOR

REF. NO.	PART NO.	DESCRIPTION	Q'TY	REMARKS
1	1UA-85510-50	STATOR ASSY	1	
2	1UA-85550-50	ROTOR ASSY	1	
3	90153-06007	SCREW, hexagon	3	
4	90201-06042	WASHER, plate	3	
5	90179-12323	NUT	1	

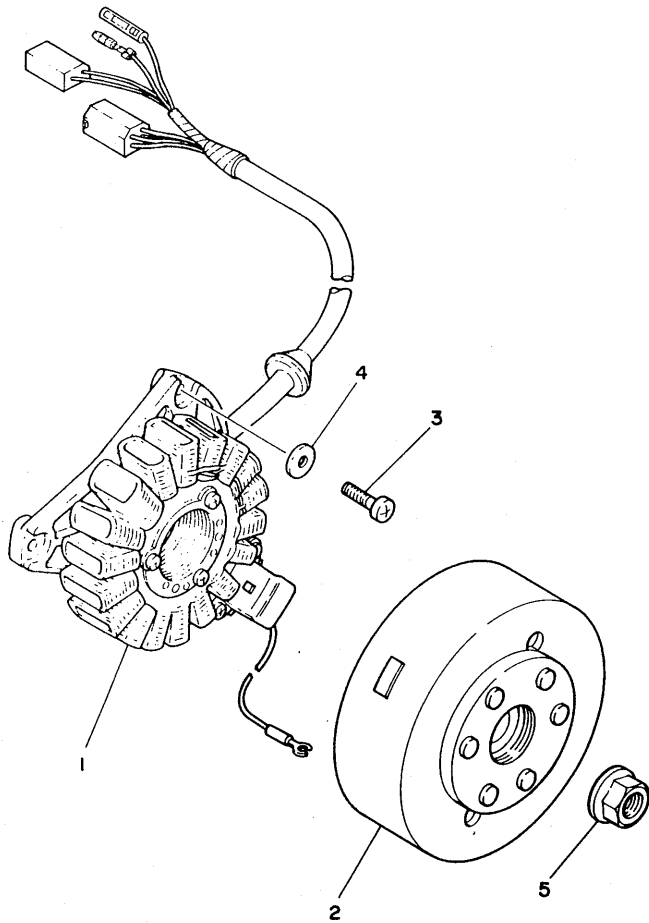

IWT 310-6350

E6

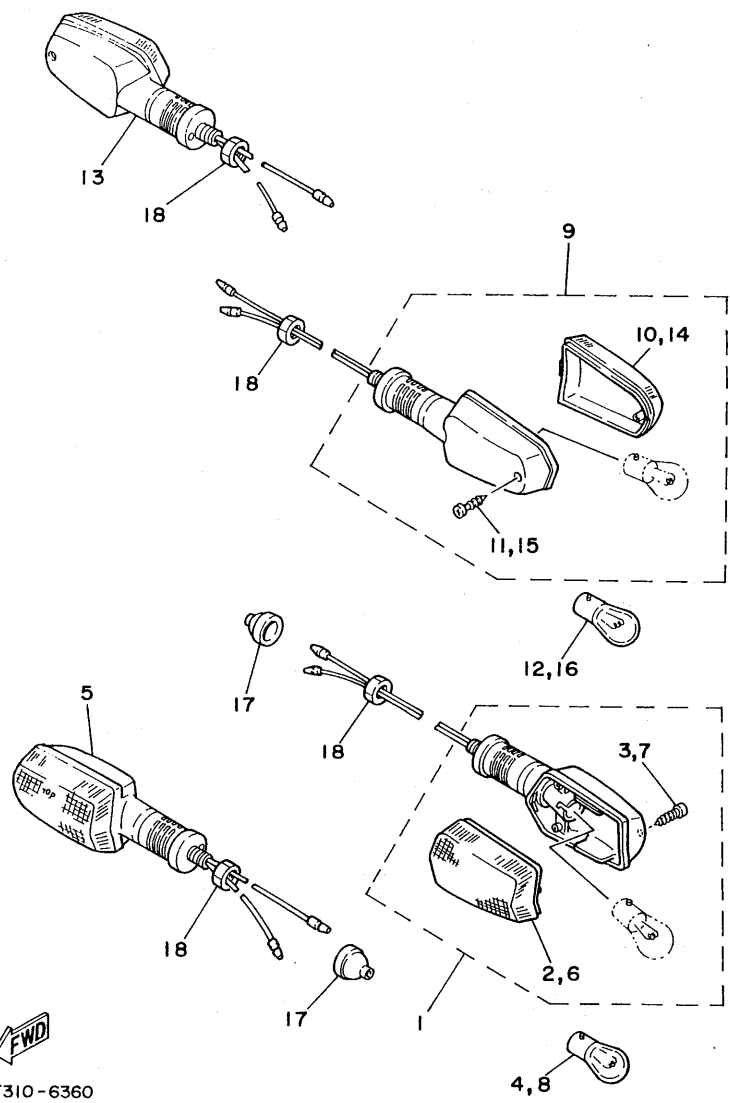

IWT310-6360

FIG. 35 FLASHER LIGHT

REF. NO.	PART NO.	DESCRIPTION	Q'TY	REMARKS
1	51J-83310-00	FRONT FLASHER LIGHT ASSY 1	1	
2	51L-83332-01	.LENS, flasher	1	
3	97706-40620	.SCREW, tapping	1	
4	*	BULB, flasher (12V-21W)	1	LM
5	51J-83320-00	FRONT FLASHER LIGHT ASSY 2	1	
6	51L-83332-01	.LENS, flasher	1	
7	97706-40620	.SCREW, tapping	1	
8	*	BULB, flasher (12V-21W)	1	LM
9	1VU-83330-00	REAR FLASHER LIGHT ASSY 1	1	
10	1VU-83332-00	.LENS, flasher	1	
11	97706-40620	.SCREW, tapping	1	
12	*	BULB, flasher (12V-21W)	1	LM
13	1VU-83340-00	REAR FLASHER LIGHT ASSY 2	1	
14	1VU-83342-00	.LENS, flasher 2	1	
15	97706-40620	.SCREW, tapping	1	
16	*	BULB, flasher (12V-21W)	1	LM
17	10V-83365-00	CAP	2	
18	95316-12700	NUT	4	

E7

FIG. 36 METER

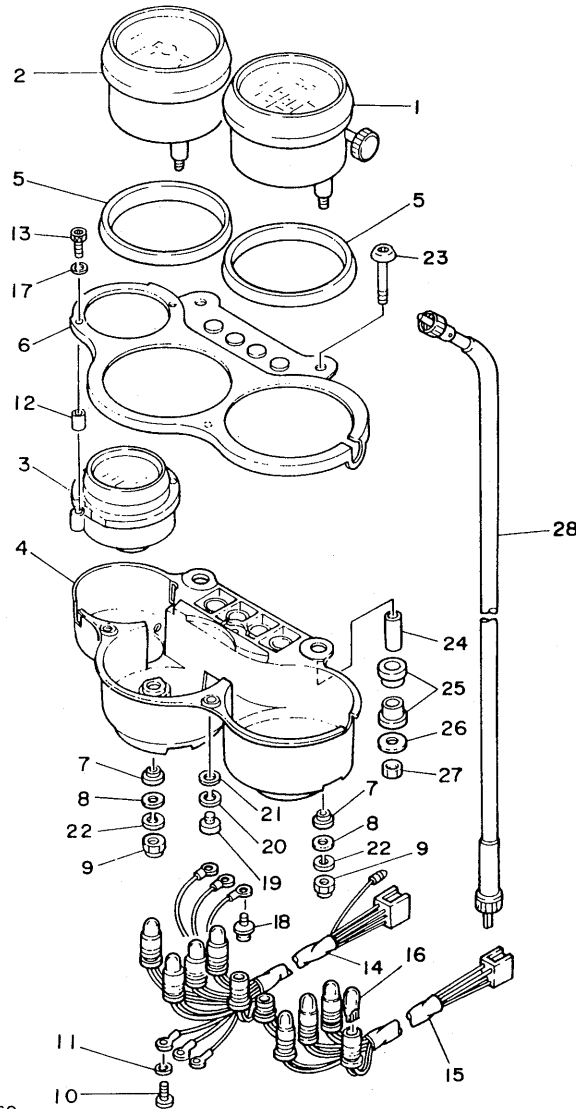

1UA300-6360

REF. NO.	PART NO.	DESCRIPTION	Q'TY	REMARKS
1	57V-83570-F0	SPEEDOMETER ASSY	1	
2	47X-83540-00	TACHOMETER ASSY	1	
3	1AR-83590-00	WATER TEMPERATURE ASSY	1	
4	1AR-83579-01	COVER, meter 2	1	
5	1AR-83513-00	DAMPER	2	
6	1AR-83611-00	PANEL, meter	1	
7	584-83523-00	DAMPER	4	
8	90201-052E2	WASHER, plate	4	
9	95306-05800	NUT, spring	4	
10	98501-03012	SCREW, pan head	3	
11	92990-03100	WASHER, spring	3	
12	1AR-83522-00	COLLAR	1	
13	91316-03016	BOLT	2	
14	1JF-83509-00	SOCKET CORD ASSY	1	
15	1AR-83520-00	SOCKET CORD ASSY	1	
16	4G1-84744-00	BULB (12V 3.4W)	8	
17	92990-03100	WASHER, spring	2	
18	90159-03102	SCREW, with washer	3	
19	98506-04008	SCREW, pan head	3	
20	92906-04100	WASHER, spring	3	
21	92906-04600	WASHER, plate	3	
22	92906-05100	WASHER, spring	4	
23	90110-06098	BOLT, hexagon socket head	2	
24	90387-06676	COLLAR	2	
25	584-83541-00	DAMPER	4	
26	90201-06380	WASHER, plate	2	
27	95306-06600	NUT	2	
28	11L-83550-00	SPEEDOMETER CABLE ASSY	1	

E8

FIG. 37 HEADLIGHT

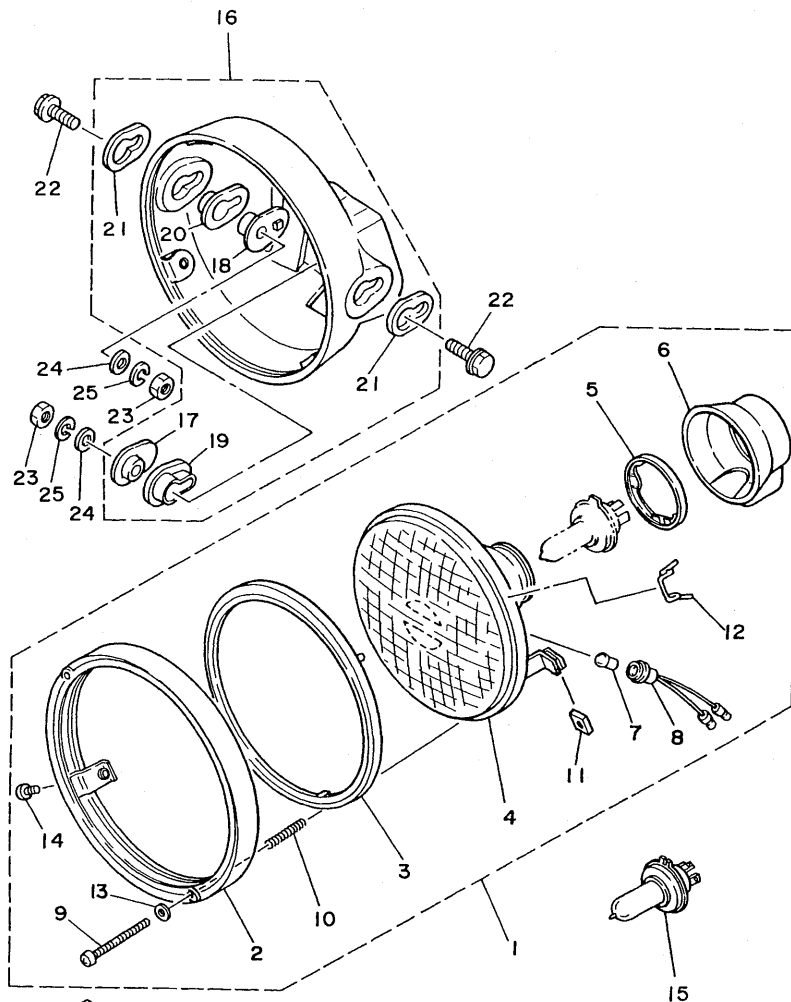

IARO10-4370

REF. NO.	PART NO.	DESCRIPTION	Q'TY	REMARKS
1	1JF-84303-G0	HEADLIGHT UNIT ASSY	1	
2	1AR-84315-00	.RIM, headlight	1	
3	29L-84395-00	.RING, retaining	1	
4	31K-84320-G0	.LENS ASSY	1	
5	2F9-84375-00	.FITTING PLATE, bulb	1	
6	2F9-84397-01	.COVER, socket	1	
7	4E2-84347-00	.BULB (12V-4W)	1	
8	457-84146-85	.SOCKET, pilot light	1	
9	10X-84131-00	.SCREW, rim adjuster	2	
10	341-84332-60	.SPRING, screw	2	
11	198-84334-60	.NUT, adjusting	2	
12	14T-84124-00	.SPRING, set	1	
13	1AR-84327-00	.WASHER, special	2	
14	98506-05012	.SCREW, pan head	2	
15	*	BULB (12V-60/55W)	1	LM
16	29L-84330-00	BODY ASSY	1	
17	5G2-84388-00	.COLLAR 1	1	
18	5G2-84398-00	.COLLAR 2	1	
19	5G2-84366-00	.DAMPER, headlight 1	1	
20	5G2-84367-00	.DAMPER, headlight 2	1	
21	5G2-84368-00	.DAMPER 3	2	
22	95806-08030	BOLT, flange	2	
23	95301-08600	NUT	2	
24	92901-08200	WASHER, plain	2	
25	92990-08100	WASHER, spring	2	

E9

FIG. 38 TAILLIGHT

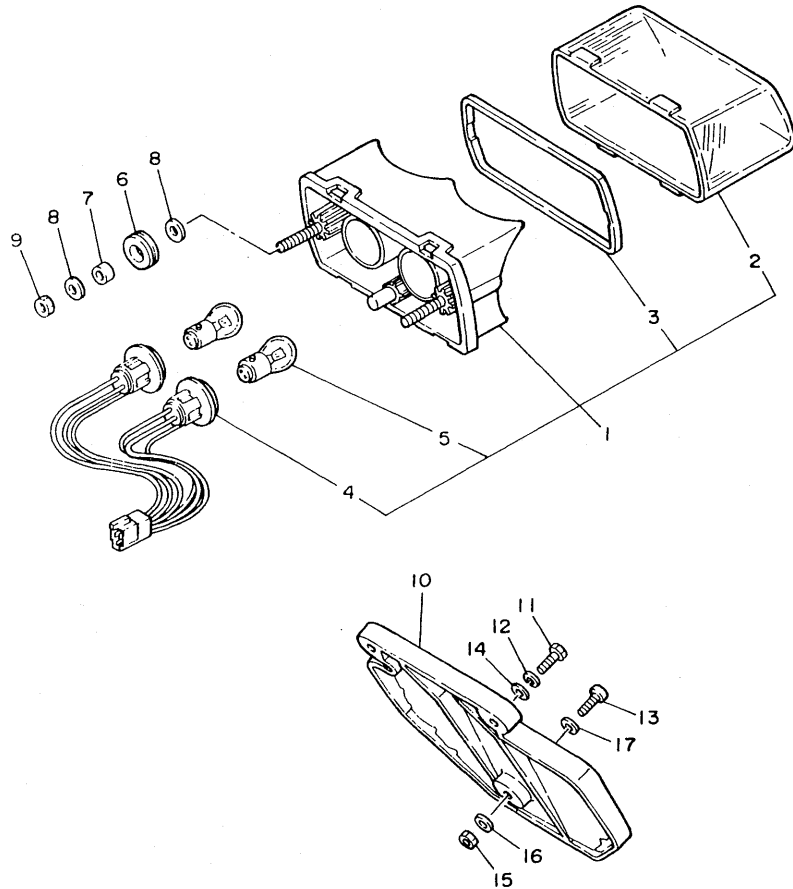

REF. NO.	PART NO.	DESCRIPTION	Q'TY	REMARKS
1	47X-84710-E0	TAILLIGHT UNIT ASSY	1	
2	47X-84721-00	.LENS, taillight	1	
3	47X-84723-00	.GASKET, tail lens	1	
4	47X-84735-00	.CORD ASSY	1	
5	31L-84714-00	.BULB, taillight (12V-21/5W)	2	
6	90480-18276	GROMMET	2	
7	90387-06694	COLLAR	2	
8	90201-063J2	WASHER, plate	4	
9	95302-06600	NUT	2	
10	29L-84751-00	BRACKET, licence	1	
11	97306-06020	BOLT	2	
12	92906-06100	WASHER, spring	2	
13	92506-06020	SCREW, pan head	1	
14	90201-06059	WASHER, plate	2	
15	95302-06600	NUT	1	
16	90201-06052	WASHER, plate	1	
17	90201-062A8	WASHER, plate	1	



IWT310-6390

E10

FIG. 39 HANDLE SWITCH. LEVER

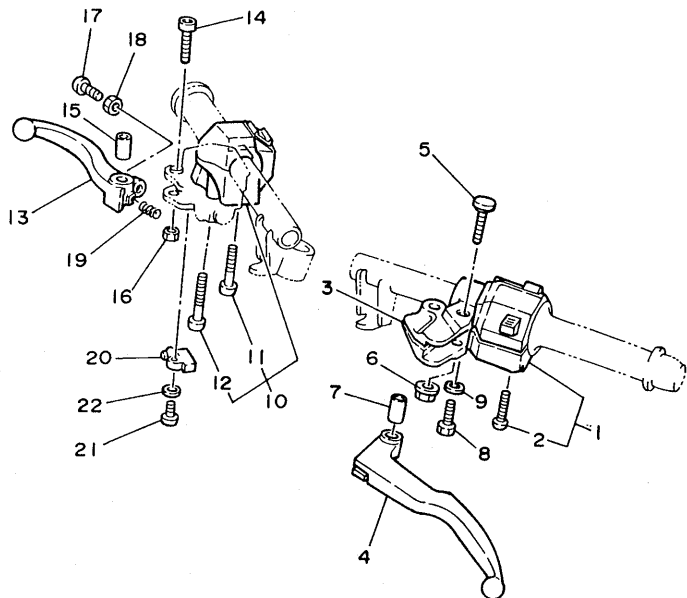

REF. NO.	PART NO.	DESCRIPTION	Q'TY	REMARKS
1	47X-83972-00	SWITCH, handle 4	1	
2	98506-05035	.SCREW, pan head	2	
3	29L-82911-01	HOLDER, lever 1	1	
4	29L-83912-01	LEVER 1	1	
5	31A-83945-00	BOLT, lever	1	
6	95706-06100	NUT, flange	1	
7	31A-83913-00	COLLAR, lever 1	1	
8	97306-06025	BOLT	1	
9	92906-06100	WASHER, spring	1	
10	1UA-83975-00	SWITCH, handle 2	1	
11	98506-05040	.SCREW, pan head	1	
12	98506-05045	.SCREW, pan head	1	
13	36Y-83922-00	LEVER 2	1	
14	90110-06074	BOLT, hexagon socket head	1	
15	36Y-83913-00	COLLAR, lever 1	1	
16	95606-06100	NUT, u	1	
17	90149-06153	SCREW	1	
18	90170-06010	NUT	1	
19	90501-10312	SPRING, compression	1	
20	36Y-83980-00	FRONT STOP SWITCH ASSY	1	
21	98506-04018	SCREW, pan head	1	
22	92906-04600	WASHER, plate	1	



IWT310-6400

E11

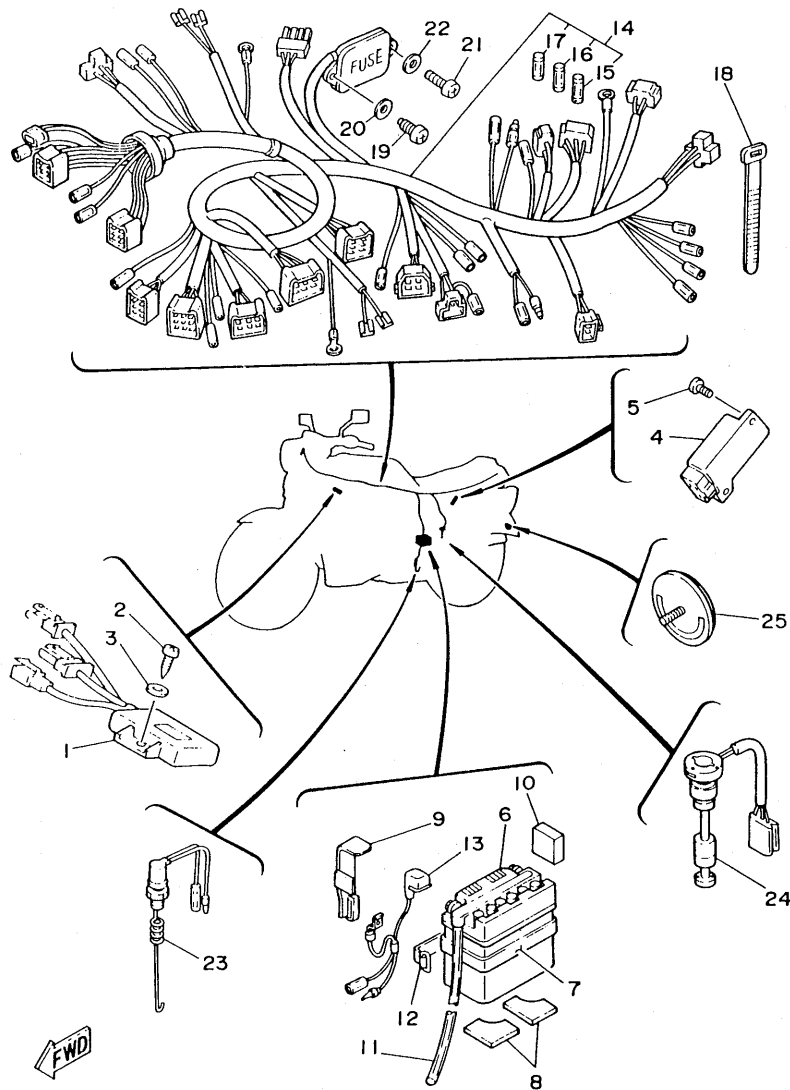

IUA351-6400

FIG. 40 ELECTRICAL 1

REF. NO.	PART NO.	DESCRIPTION	Q'TY	REMARKS
1	1UA-85540-50	C.D.I. UNIT ASSY	1	
2	97702-60520	SCREW, tapping	2	
3	92990-06200	WASHER, plain	2	
4	47X-81960-A0	RECTIFIER & REGULATOR ASSY	1	
5	92501-06012	SCREW, pan head	2	
6	43F-82110-60	BATTERY ASSY (GM4A-3B)	1	
7	1UA-82124-00	BAND, battery	1	
8	1UA-82122-00	SEAT, battery	2	
9	29L-82129-00	COVER, battery	1	
10	1UA-82123-00	SEAT, battery	1	
11	90445-08336	HOSE	1	
12	29L-82131-00	BAND, battery	1	
13	4L0-82117-00	WIRE, lead	1	
14	1UA-82590-00	WIRE HARNESS ASSY	1	
15	1A0-82161-00	.FUSE (20A)	1	
16	4X7-82151-00	.FUSE (15A)	2	
17	5G2-82151-00	.FUSE (5A)	1	
18	437-83936-10	BAND, switch cord	1	
19	97780-60116	SCREW, tapping	1	
20	92901-06200	WASHER, plain	1	
21	92501-06014	SCREW, pan head	1	
22	92901-06600	WASHER, plate	1	
23	1T2-82530-00	STOP SWITCH ASSY	1	
24	34X-85720-00	OIL LEVEL GAUGE ASSY	1	
25	449-85131-02	REFLECTOR, rear 1	1	

E12

FIG. 41 ELECTRICAL 2

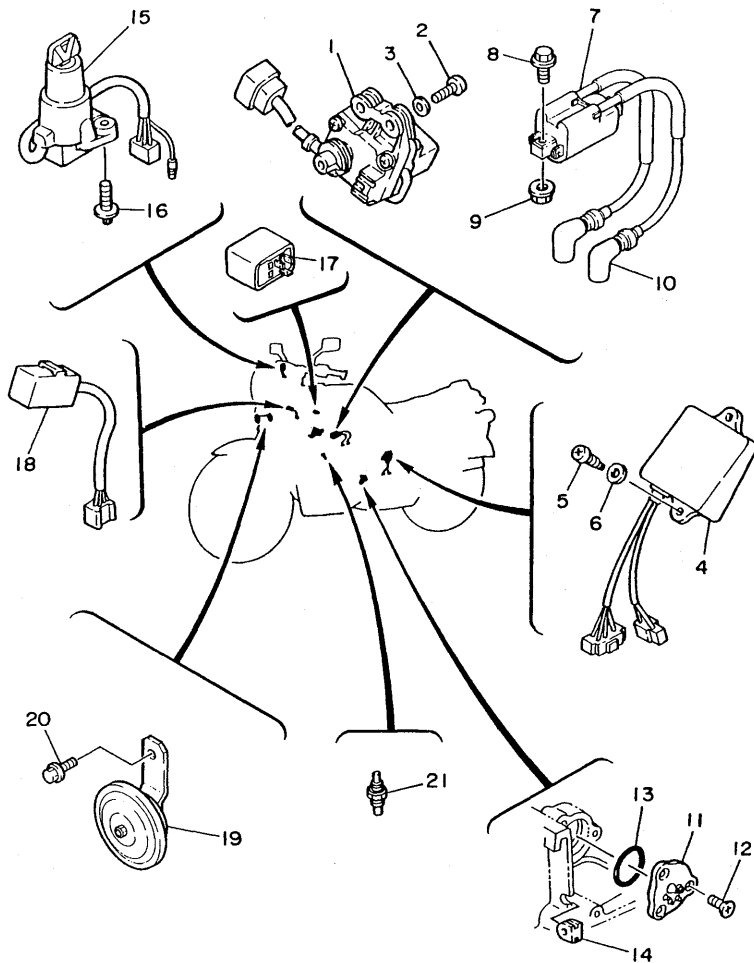

REF. NO.	PART NO.	DESCRIPTION	Q'TY	REMARKS
1	1UA-85820-00	SERVO MOTOR ASSY	1	
2	92501-06025	SCREW, pan head	2	
3	90201-06067	WASHER, plate	2	
4	1UA-85830-00	CONTROL UNIT ASSY	1	
5	97702-60116	SCREW, tapping	2	
6	92990-06200	WASHER, plain	2	
7	1UA-82310-50	IGNITION COIL ASSY	1	
8	98002-06018	BOLT	2	
9	95702-06100	NUT, flange	1	
10	1M1-82370-21	PLUG CAP ASSY	2	WITH NOISE SUPPRESSOR
11	1L9-82540-00	NEUTRAL SWITCH ASSY	1	
12	98702-05012	SCREW, flat head	3	
13	93210-29147	O-RING	1	
14	90480-01148	GROMMET	1	
15	1UA-82501-00	MAIN SWITCH STEERING LOCK	1	
16	90109-06614	BOLT	2	
17	4K0-83350-20	FLASHER RELAY ASSY	1	
18	1A0-83395-03	FLASHER CANCELLING UNIT	1	
19	1UA-83371-00	HORN	1	
20	98006-08012	BOLT	1	
21	11H-83591-00	THERMO UNIT	1	



IUA300-6410

E13

INDIVIDUAL SPEC.

FOR AUSTRIA

The following pages provides a listing of only the parts that meet the specifications peculiar to your market. For those parts not appearing in these pages, refer to the "GENERAL SPEC" section.

FIG. 42 ALTERNATE (ENGINE)

REF. NO.	PART NO.	DESCRIPTION	Q'TY	REMARKS
1	29L-12467-00	COVER, radiator	*	
2	33E-12467-00	COVER, radiator	1	

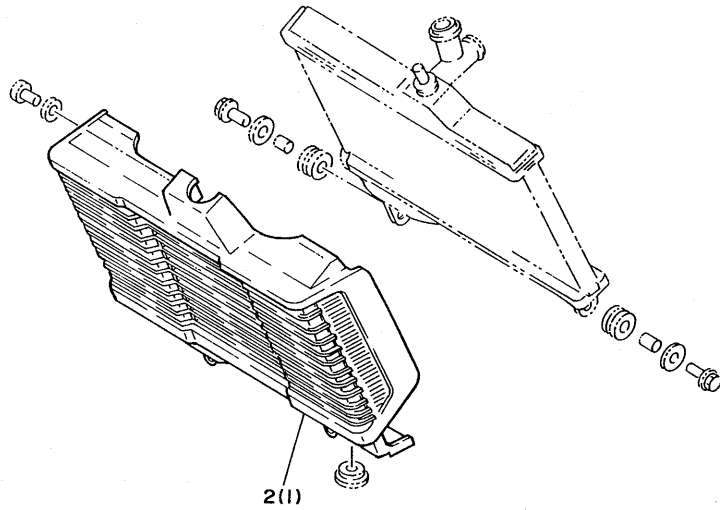

IUA300-6420

* For convenience of reference:

Disregard the items asterisked (*) in the "QTY" column. These are intended for GENERAL SPEC, and NOT for INDIVIDUAL SPEC.

E15

FIG. 43 ALTERNATE (CHASSIS)

REF. NO.	PART NO.	DESCRIPTION	Q'TY	REMARKS
1	1UA-21610-00	REAR FENDER COMP.	*	
2	1WV-21610-00	REAR FENDER COMP.	1	
3	1UA-24730-00	DOUBLE SEAT ASSY	*	UR BLACK
	1XG-24730-00	DOUBLE SEAT ASSY	1	UR BLACK
	1UA-24730-20	DOUBLE SEAT ASSY	*	UR RED
	1XG-24730-20	DOUBLE SEAT ASSY	1	UR RED
4	1UA-24731-00	.COVER, seat	1	UR BLACK
	1UA-24731-20	.COVER, seat	1	UR RED
5	29L-27311-00-33	STAND, side	*	YAMAHA BLACK
6	1UA-27311-00-33	STAND, side	1	YAMAHA BLACK

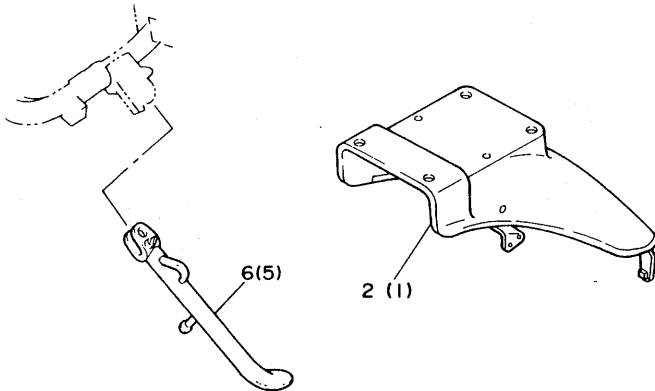
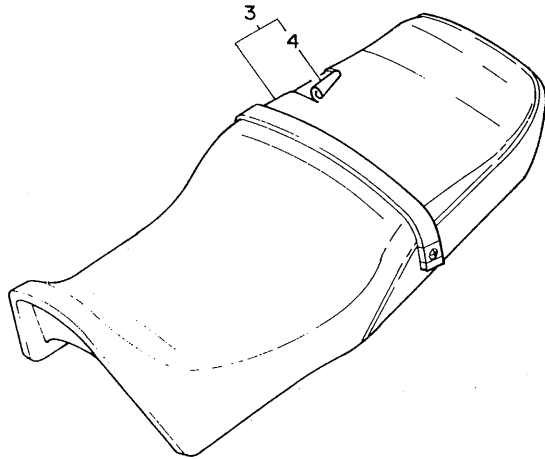

IUA300-6430

* For convenience of reference:

Disregard the items asterisked (*) in the "QTY" column. These are intended for GENERAL SPEC, and NOT for INDIVIDUAL SPEC.

F2

FIG. 44 ALTERNATE (ELECTRICAL)

REF. NO.	PART NO.	DESCRIPTION	Q'TY	REMARKS
1	20G-85110-00	FRONT REFLECTOR ASSY	4	
2	95702-05500	NUT, flange	4	
3	1UA-82590-00	WIRE HARNESS ASSY	*	
4	1UA-82590-10	WIRE HARNESS ASSY	1	
5	1A0-82161-00	.FUSE (20A)	1	
6	4X7-82151-00	.FUSE (15A)	2	
7	5G2-82151-00	.FUSE (5A)	1	
8	33E-82566-00	SWITCH, side stand	1	
9	98706-05016	SCREW, flat head	2	
10	4Y3-85590-M0	CONTROL UNIT ASSY	1	
11	97702-60520	SCREW, tapping	1	
12	92990-06100	WASHER, spring	1	
13	92990-06600	WASHER, plate	1	

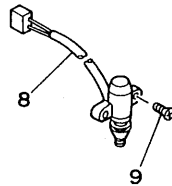
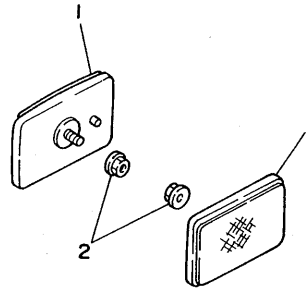
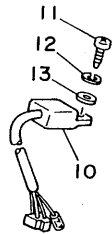
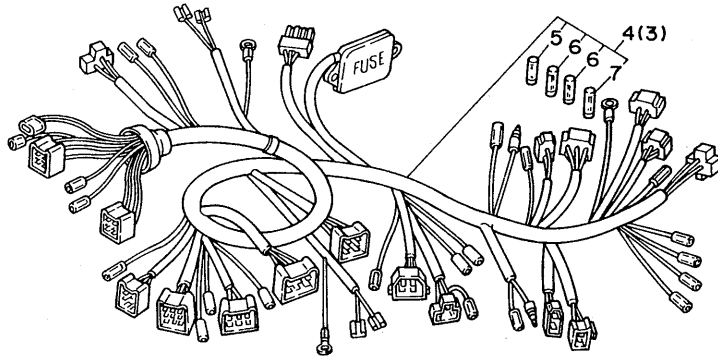

FWD

IWT300-6440

* For convenience of reference:

Disregard the items asterisked (*) in the "QTY" column. These are intended for GENERAL SPEC. and NOT for INDIVIDUAL SPEC.

F3

FOR DENMARK

FOR NORWAY

The following pages provides a listing of only the parts that meet the specifications peculiar to your market. For those parts not appearing in these pages, refer to the "GENERAL SPEC" section.

FIG. 45 ALTERNATE (CHASSIS)

REF. NO.	PART NO.	DESCRIPTION	Q'TY	REMARKS
1	29L-27311-00-33	STAND, side	*	YAMAHA BLACK
2	1UA-27311-00-33	STAND, side	1	YAMAHA BLACK
3	1UA-21610-00	REAR FENDER COMP.	*	
4	1XA-21610-00	REAR FENDER COMP.	1	

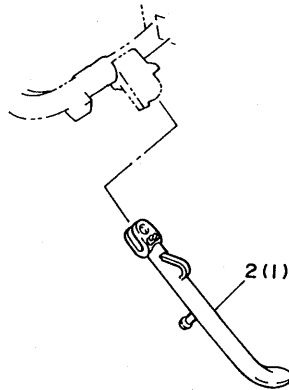
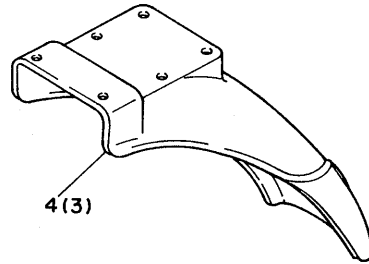

IWT300-6450

* For convenience of reference:
 Disregard the items asterisked (*) in the "QTY" column. These are intended for
 GENERAL SPEC, and NOT for INDIVIDUAL SPEC.

F5

FIG. 46 ALTERNATE (ELECTRICAL)

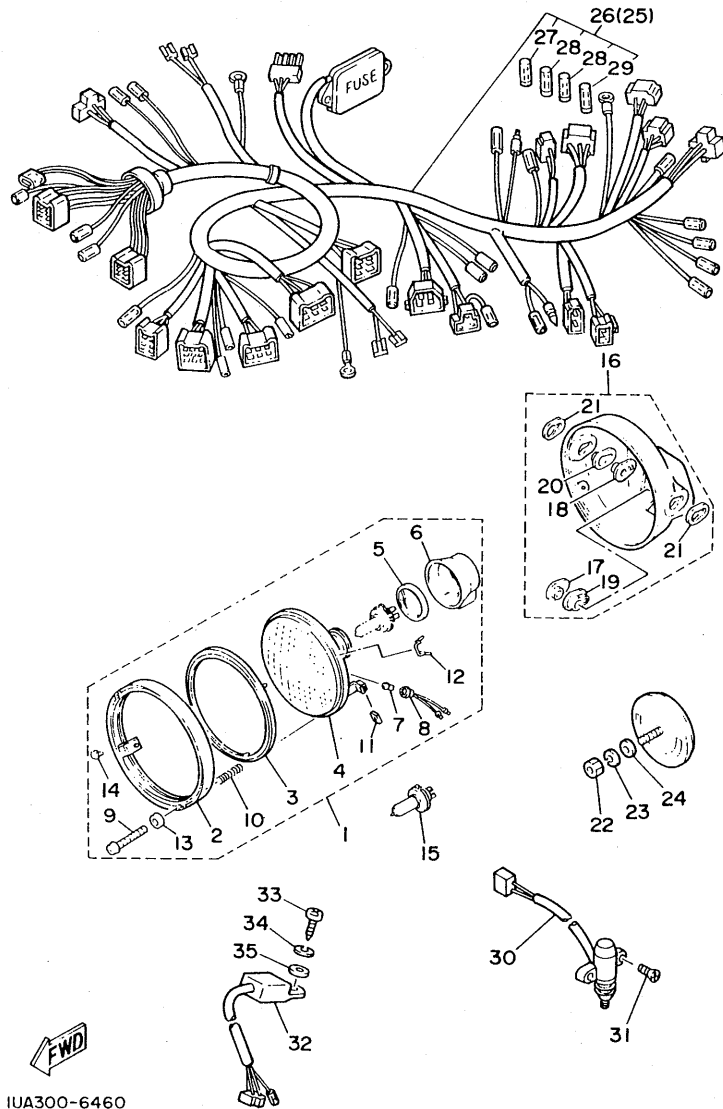

IUA300-6460

* For convenience of reference:

Disregard the items asterisked (*) in the "QTY" column. These are intended for GENERAL SPEC, and NOT for INDIVIDUAL SPEC.

REF. NO.	PART NO.	DESCRIPTION	Q'TY	REMARKS
1	1JF-84303-G0	HEADLIGHT UNIT ASSY	1	
2	1AR-84315-00	.RIM, headlight	1	
3	29L-84395-00	.RING, retaining	1	
4	31K-84320-G0	.LENS ASSY	1	
5	2F9-84375-00	.FITTING PLATE, bulb	1	
6	2F9-84397-01	.COVER, socket	1	
7	4E2-84347-00	.BULB (12V 4W)	1	
8	457-84146-85	.SOCKET, pilot light	1	
9	10X-84131-00	.SCREW, rim adjuster	2	
10	341-84332-60	.SPRING, screw	2	
11	198-84334-60	.NUT, adjusting	2	
12	14T-84124-00	.SPRING, set	1	
13	1AR-84327-00	.WASHER, special	2	
14	98506-05012	.SCREW, pan head	2	
15	*	BULB (12V-60/55W)	1	LM
16	29L-84330-00	BODY ASSY	1	
17	5G2-84388-00	.COLLAR 1	1	
18	5G2-84398-00	.COLLAR 2	1	
19	5G2-84366-00	.DAMPER, headlight 1	1	
20	5G2-84367-00	.DAMPER, headlight 2	1	
21	5G2-84368-00	.DAMPER 3	2	
22	95302-05600	NUT	1	
23	92990-05100	WASHER, spring	1	
24	92990-05200	WASHER, plain	1	
25	1UA-82590-00	WIRE HARNESS ASSY	*	
26	1UA-82590-10	WIRE HARNESS ASSY	1	
27	1A0-82161-00	.FUSE (20A)	1	
28	4X7-82151-00	.FUSE (15A)	2	

F6

FIG. 46 ALTERNATE (ELECTRICAL)

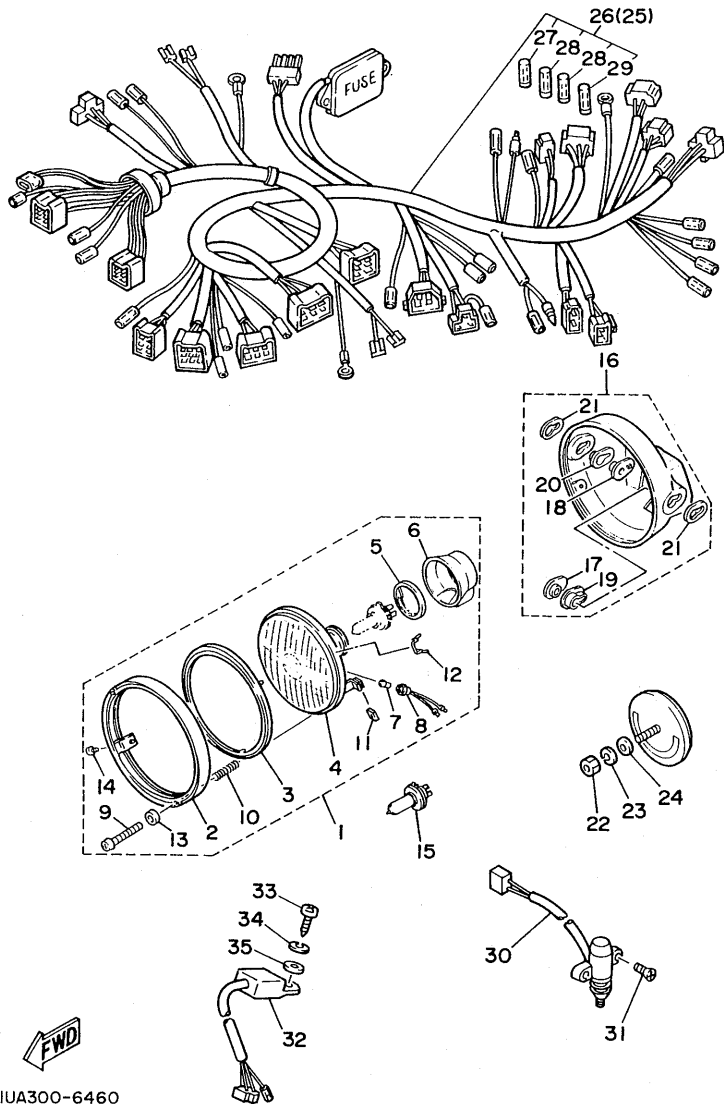

REF. NO.	PART NO.	DESCRIPTION	Q'TY	REMARKS
29	5G2-82151-00	.FUSE (5A)	1	
30	33E-82566-00	SWITCH, side stand	1	
31	98706-05016	SCREW, flat head	2	
32	4Y3-85590-M0	CONTROL UNIT ASSY	1	
33	97702-60520	SCREW, tapping	1	
34	92990-06100	WASHER, spring	1	
35	92990-06600	WASHER, plate	1	

IUA300-6460

F7

FOR SWEDEN

The following pages provides a listing of only the parts that meet the specifications peculiar to your market. For those parts not appearing in these pages, refer to the "GENERAL SPEC" section.

FIG. 47 ALTERNATE (ENGINE)

REF. NO.	PART NO.	DESCRIPTION	Q'TY	REMARKS
1	1UA-14710-00	MUFFLER ASSY 1	*	
2	1UA-14710-10	MUFFLER ASSY 1	1	
3	92906-06600	.WASHER, plate	1	
4	90101-06576	.BOLT	1	
5	1UA-14720-00	MUFFLER ASSY 2	*	
6	1UA-14720-10	MUFFLER ASSY 2	1	
7	92906-06600	.WASHER, plate	1	
8	90101-06576	.BOLT	1	

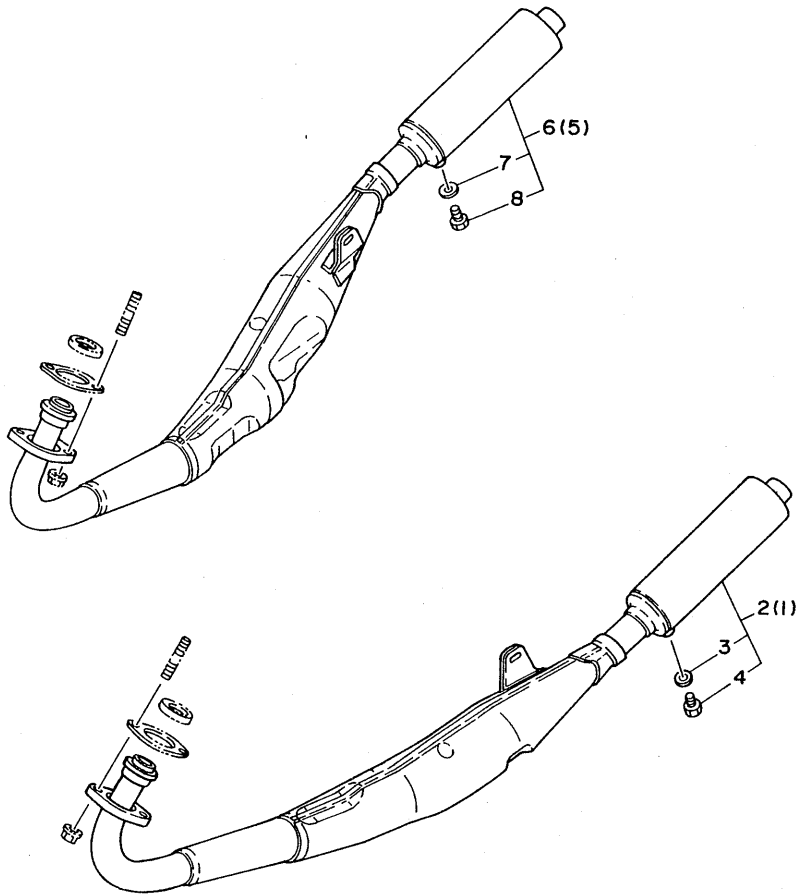

IWT300-6490

* For convenience of reference:

Disregard the items asterisked (*) in the "QTY" column. These are intended for GENERAL SPEC, and NOT for INDIVIDUAL SPEC.

F9

FIG. 48 ALTERNATE (CHASSIS)

REF. NO.	PART NO.	DESCRIPTION	Q'TY	REMARKS
1	29L-27311-00-33	STAND, side	*	YAMAHA BLACK
2	1UA-27311-00-33	STAND, side	1	YAMAHA BLACK
3	1UA-21610-00	REAR FENDER COMP.	*	
4	1XA-21610-00	REAR FENDER COMP.	1	

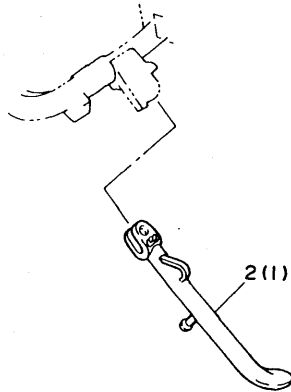
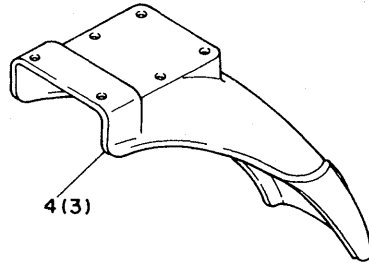

IWT300-6450

* For convenience of reference:

Disregard the items asterisked (*) in the "QTY" column. These are intended for GENERAL SPEC, and NOT for INDIVIDUAL SPEC.

F10

FIG. 49 ALTERNATE (ELECTRICAL)

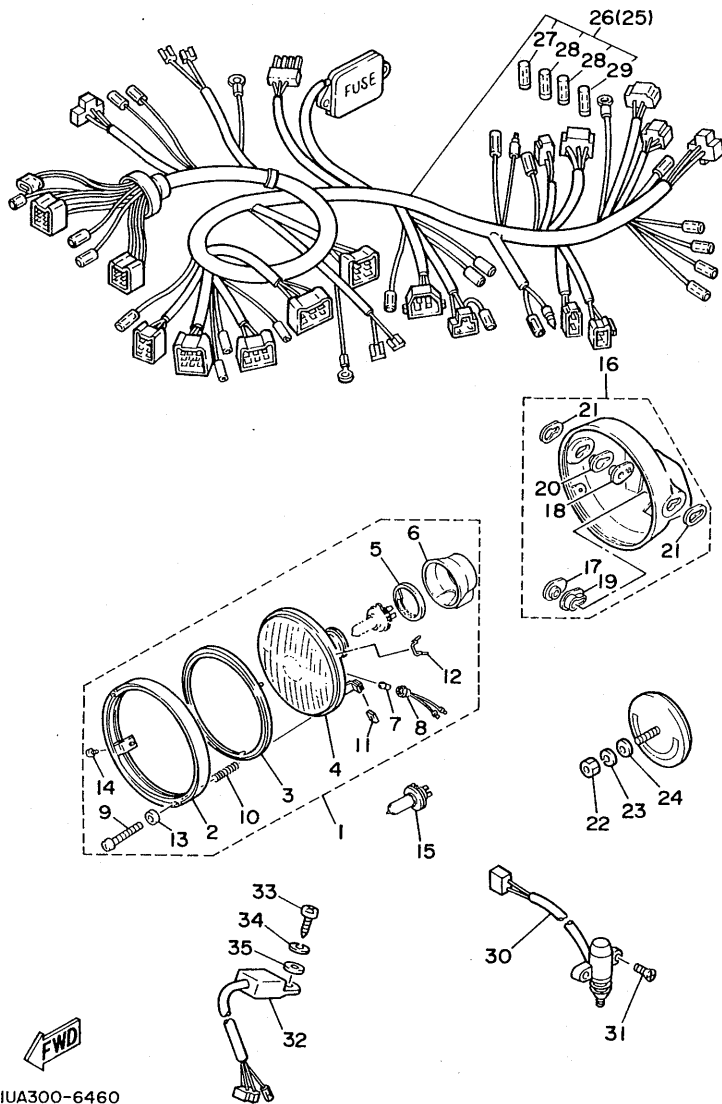

IUA300-6460

* For convenience of reference:

Disregard the items asterisked (*) in the "QTY" column. These are intended for GENERAL SPEC, and NOT for INDIVIDUAL SPEC.

REF. NO.	PART NO.	DESCRIPTION	Q'TY	REMARKS
1	1JF-84303-G0	HEADLIGHT UNIT ASSY	1	
2	1AR-84315-00	.RIM, headlight	1	
3	29L-84395-00	.RING, retaining	1	
4	31K-84320-G0	.LENS ASSY	1	
5	2F9-84375-00	.FITTING PLATE, bulb	1	
6	2F9-84397-01	.COVER, socket	1	
7	4E2-84347-00	.BULB (12V 4W)	1	
8	457-84146-85	.SOCKET, pilot light	1	
9	10X-84131-00	.SCREW, rim adjuster	2	
10	341-84332-60	.SPRING, screw	2	
11	198-84334-60	.NUT, adjusting	2	
12	14T-84124-00	.SPRING, set	1	
13	1AR-84327-00	.WASHER, special	2	
14	98506-05012	.SCREW, pan head	2	
15	*	BULB (12V-60/55W)	1 LM	
16	29L-84330-00	BODY ASSY	1	
17	5G2-84388-00	.COLLAR 1	1	
18	5G2-84398-00	.COLLAR 2	1	
19	5G2-84366-00	.DAMPER, headlight 1	1	
20	5G2-84367-00	.DAMPER, headlight 2	1	
21	5G2-84368-00	.DAMPER 3	2	
22	95302-05600	NUT	1	
23	92990-05100	WASHER, spring	1	
24	92990-05200	WASHER, plain	1	
25	1UA-82590-00	WIRE HARNESS ASSY	*	
26	1UA-82590-10	WIRE HARNESS ASSY	1	
27	1A0-82161-00	.FUSE (20A)	1	
28	4X7-82151-00	.FUSE (15A)	2	

F11

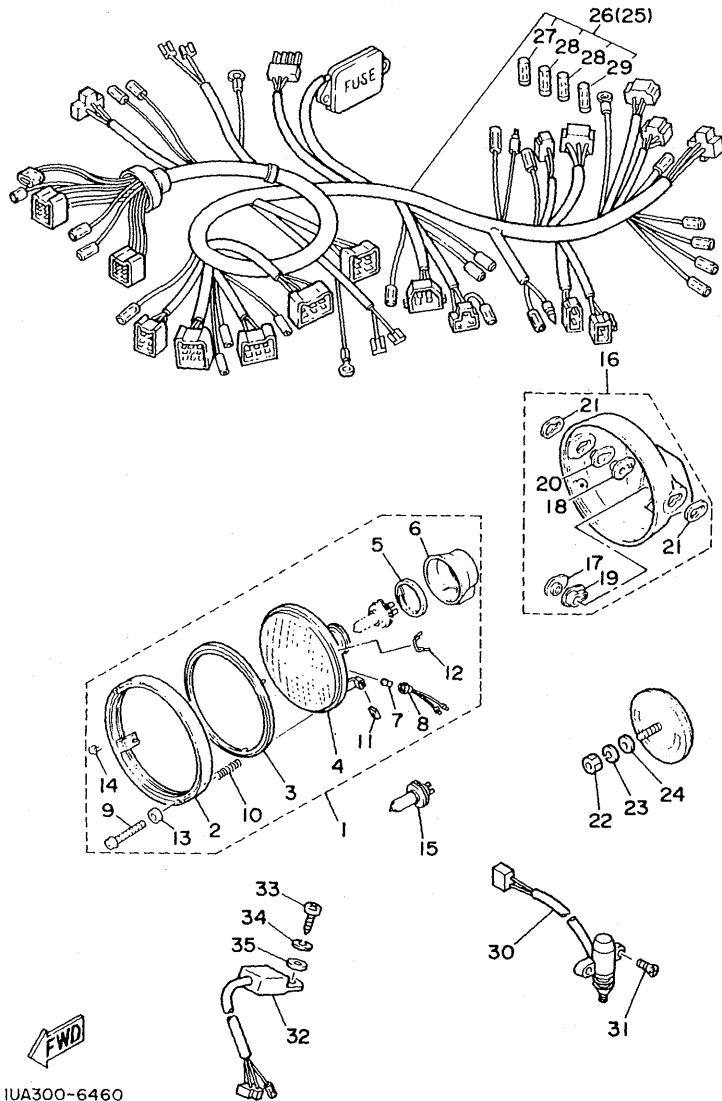

IUA300-6460

FIG. 49 ALTERNATE (ELECTRICAL)

REF. NO.	PART NO.	DESCRIPTION	Q'TY	REMARKS
29	5G2-82151-00	.FUSE (5A)	1	
30	33E-82566-00	SWITCH, side stand	1	
31	98706-05016	SCREW, flat head	2	
32	4Y3-85590-M0	CONTROL UNIT ASSY	1	
33	97702-60520	SCREW, tapping	1	
34	92990-06100	WASHER, spring	1	
35	92990-06600	WASHER, plate	1	

F12

INDEX

(GENERAL SPEC.)

NUMERICAL INDEX

PART NO.	GRID NO.	PART NO.	GRID NO.	PART NO.	GRID NO.	PART NO.	GRID NO.	PART NO.	GRID NO.	PART NO.	GRID NO.
36Y-W0041-00	E- 2	4L0-12435-00	B- 6	137-14153-00	B-12	4L0-15660-00	C- 3	29L-18535-00	C- 8	51L-22110-00-35	C-15
29L-W0042-50	E- 5	4L0-12436-00	B- 5	802-14161-00	B-12	4L0-15666-00	C- 3	29L-18540-00	C- 8	26H-22128-00	C-15
51L-W0046-00	D-11	29L-12446-00	B- 6	3X3-14169-00	B-12	248-15668-00	C- 3	278-18542-00	C- 8	26H-22129-00	C-15
	D-11	4L0-12450-01	B- 5	4U5-14171-00	B-12	4L0-16111-00	C- 4	3R4-18561-00	C- 8	4X7-22129-00	C-15
	D-14	4L0-12459-00	B- 5	304-14184-00	B-12	31K-16150-10	C- 4	4L0-18562-00	C- 8	29L-22141-00	C-15
51L-W0047-00	D-11	29L-1246A-00	B- 7	4L0-14185-00	B-12	360-16154-00	C- 4	278-18566-00	C- 8	29L-22151-00	D- 2
	D-11	29L-1246E-00	B- 7	537-14186-00	B-12		C- 4	1WT-21110-00-33	C-10	31K-2217A-00	C-15
	D-14	29L-12461-00	B- 6	12R-14191-00	B-12	278-16181-01	C- 4	1UA-21171-00	C-11	29L-2217H-00	D- 3
51L-W0048-00	D-11	22W-12462-00	B- 6	4L0-14196-00	B-12	4L0-16321-01	C- 4	1UA-21243-00	C-12	31K-2217M-00	C-15
	D-11	29L-12467-00	B- 6	4L0-14197-00	B-12	498-16325-00	C- 4	1UA-21260-00	C-10	51L-22174-00	D-12
	D-14	29L-12469-00	B- 6	51L-1441F-00	B-10	29L-16351-00	C- 4	47X-21308-00	C-10	51L-22184-00	C-15
51L-W0057-00	D-11	4L0-12479-00	B- 6	51L-14411-00	B-10	29L-16356-00	C- 4	1UA-21314-00	C-10	31K-22187-00	D- 2
	D-11	29L-12481-00	B- 6	29L-14412-00	B-10	29L-16357-00	C- 4	29L-21315-01	C-10	1UA-22210-00	D- 3
	D-14	29L-12482-00	B- 7	29L-14421-00	B-10	278-16367-00	C- 4	29L-21316-00	C-10	29L-22216-00	D- 3
1UA-11111-01	B- 2	29L-12483-00	B- 7	29L-14437-00	B-10	1A0-16371-00	C- 4	4L0-21317-00	C-10	29L-22311-00	C-15
31K-11181-00	B- 2	4L0-12484-00	B- 7	29L-14451-00	B-10	29L-16380-00	C- 4	4L0-21318-00	C-10	1UA-23102-00	D- 5
31K-1131A-00	B- 2	29L-12485-00	B- 6	11H-14452-00	B-10	29L-17121-00	C- 6	1UA-21319-00	C-10	1UA-23103-00	D- 5
1UA-1131E-00	B- 3	29L-12590-00	B- 6	29L-14452-00	B-10	29L-17131-00	C- 6	4L0-21485-00	C-10	51L-23108-00	D- 6
31K-1131F-00	B- 2	1UA-13101-00	B- 8	29L-14453-00	B-10	29L-17151-00	C- 6		C-10	1UA-23110-00	D- 5
	B- 3	8Y0-13116-00	B- 8	29L-14465-00	B-10	29L-17161-00	C- 6	51L-21510-00-7X	C-11		D- 5
29L-1131H-00	B- 3	137-13137-00-03	B- 8	29L-14613-00	B-14	4L0-17211-01	C- 6	51L-21510-00-8X	C-11	1UA-23111-00	D- 5
29L-1131J-00	B- 3	137-13137-00-05	B- 8	29L-14643-00	B-14	4L0-17221-01	C- 6	1A8-21518-00	C-11		D- 6
29L-1131M-00	B- 2	137-13137-00-10	B- 8	1UA-14710-00	B-14	29L-17231-00	C- 6	1UA-21610-00	C-11	51L-23118-00	D- 5
1UA-1131R-00	B- 2	137-13138-01	B- 8	1UA-14720-00	B-14	4L0-17241-01	C- 6	29L-21629-00	C-11		D- 6
31K-1131U-00	B- 2	278-13169-00	B- 8	1UA-1490J-00	B-12	29L-17251-10	C- 6	1UA-21636-00	C-13	1E7-23119-00	D- 5
1UA-1131V-00	B- 2	4L0-13174-00	B- 9	51L-14987-00	B-12	29L-17261-10	C- 6	1UA-21636-10	C-13		D- 5
31K-1132A-00	B- 3	4L0-13175-02	B- 8	29L-15100-03	B-15	29L-17411-00	C- 6	1UA-21645-00	C-12	51L-23125-00	D- 5
29L-1132E-00	B- 2	1E7-13176-00	B- 8	4L0-15316-00	B-15	164-17417-00-10	C- 3	1UA-21651-00-GE	C-12		D- 6
1UA-1132I-00	B- 2	4L0-13178-00	B- 8	31K-15317-00	C- 2	29L-17421-00	C- 6	1UA-21651-00-6G	C-12	51L-23126-00-38	D- 5
29L-1133E-00	B- 3	353-13552-01	B- 8	4L0-15326-00	B-15	278-17424-01	B- 4	1UA-21711-00-GE	C-12	10V-23135-00	D- 5
29L-1135I-00	B- 2		B- 8	48H-15327-00	C- 2		C- 7	1UA-21711-00-6G	C-12		D- 6
29L-11400-30	B- 4	31K-13565-00	B-10	4L0-15328-00	B-15	278-17425-00	C- 6	1UA-21721-00-GE	C-12	51L-23136-00-38	D- 5
29L-11409-30	B- 4	1UA-13610-00	B-10	48H-15337-00	B-15	1M1-17461-70	C- 7	1UA-21721-00-6G	C-12	1UA-23141-00	D- 5
29L-11412-00	B- 4	1UA-13613-00	B-10	137-15353-00	B-15	4L0-17471-00	C- 6	1WT-2173E-00	C-12		D- 5
29L-11442-10	B- 4	1UA-13616-00	B-10	4L0-15362-00	C- 2	4L0-18101-00	C- 9	1WT-2173E-20	C-12	51L-23142-00	D- 5
1UA-11610-00	B- 4	31K-13621-00	B-10	498-15371-00	B-15	1UA-18111-00	C- 9	1WT-2173F-00	C-12		D- 6
1UA-11610-10	B- 4	1UA-14101-00	B-12	29L-15410-00	C- 2	1UA-18112-00	C- 9	1WT-2173F-20	C-12	1UA-23144-00	D- 5
1UA-11610-20	B- 4	1UA-14102-00	B-12	48H-15420-00	C- 2	132-18113-01	C- 9	29L-21731-00	C-12		D- 6
1UA-11631-00-94	B- 4	23L-14103-00	B-12	29L-15421-00	C- 2	22N-18113-00	E- 4	29L-21741-00	C-12	1UA-23145-00	D- 5
4L0-11633-00	B- 4	10W-14104-00	B-12	29L-15431-00	C- 2	1UA-18115-00	C- 9	29L-21746-00	C-14		D- 6
4V2-11634-00	B- 4	48H-14107-28	B-12	4L0-15461-01	C- 2	4L0-18140-00	C- 8	29L-21751-01	C-14	1UA-23147-00	D- 5
1UA-11635-00	B- 4	29K-14112-20	B-12	1A0-15491-00	C- 2	2H9-18154-00	C- 9	29L-21766-00	C-14		D- 6
1UA-11636-00	B- 4	29K-14113-20	B-12	278-15492-01	B-15		C- 9	10V-21771-00	C-14	10V-23147-00	D- 5
29L-11651-00	B- 4	4L0-14131-00	B-12	1A0-15497-00	C- 2	1W1-18177-00	C- 8	4J2-21778-00	C-12		D- 6
31K-11915-00	B- 3	1UA-14141-28	B-12	156-15618-01	C- 3	4L0-18185-00	C- 8	1UA-21786-00	C-12	51L-23151-00	D- 5
29L-12411-00	B- 6	260-14142-25	B-12	51L-15620-01	C- 3	4L0-18511-00	C- 8	1UA-21786-10	C-12		D- 6
4L0-12422-00	B- 5	137-14143-37	B-12	4L0-15641-00	C- 3	4L0-18512-00	C- 8	4L0-21815-01	C-14	1UA-23153-00	D- 5
4L0-12428-00	B- 5	500-14146-00	B-12	4L0-15651-00	C- 3	4L0-18531-01	C- 8	29L-21870-00	C-14		D- 6

NUMERICAL INDEX

PART NO.	GRID NO.	PART NO.	GRID NO.	PART NO.	GRID NO.	PART NO.	GRID NO.	PART NO.	GRID NO.	PART NO.	GRID NO.
34X-23156-00	D- 5	41Y-24705-01	D- 9	4L0-25862-00	E- 2	1UA-28100-00	C-11	36Y-83913-00	E-11	90105-14365	D- 4
	D- 6	1UA-24730-00	D- 9	36Y-25867-00	E- 2	47X-81960-A0	E-12	36Y-83922-00	E-11	90109-06614	E-13
51L-23157-00	D- 5	1UA-24730-20	D- 9	51L-25872-50	E- 5	43F-82110-60	E-12	437-83936-10	E-12	90109-10554	D- 3
	D- 6	1UA-24731-00	D- 9	57V-25872-00	E- 2	4L0-82117-00	E-12	31A-83945-00	E-11	90109-10590	E- 4
3J3-23159-00	D- 6	1UA-24731-20	D- 9	51L-25873-00	E- 2	1UA-82122-00	E-12	47X-83972-00	E-11	90109-10737	E- 4
10V-23166-00	D- 5	1J3-24742-00	C-12	29L-25875-00	E- 5	1UA-82123-00	E-12	1UA-83975-00	E-11	90109-10739	C-15
	D- 6	31A-24760-00	D- 9	4L0-25875-00	E- 2	1UA-82124-00	E-12	36Y-83980-00	E-11	90109-10754	E- 3
1UA-23168-00	D- 5	2R6-25115-00	D-12	2R8-25876-00	E- 2	29L-82129-00	E-12	14T-84124-00	E- 9	90110-05112	D- 7
	D- 6	341-25149-00	D-10	47X-25885-00	E- 2	116-82131-00	C-11	10X-84131-00	E- 9	90110-06074	E-11
1UA-23171-00	D- 5	1UA-25168-00-FH	D-10	1A1-25894-01	E- 5	29L-82131-00	E-12	457-84146-85	E- 9	90110-06090	C-12
	D- 5	4L0-25181-00	D-10	29L-25895-00	E- 5	4X7-82151-00	E-12	1JF-84303-60	E- 9	90110-06098	E- 8
1JF-23174-00	D- 4	4L0-25190-00	D-10	51L-25919-00	D-11	56Z-82151-00	E-12	1AR-84315-00	E- 9	90110-08057	D-12
3M7-23181-00	D- 5	2U2-25315-00	D-10		D-11	1A0-82161-00	E-12	31K-84320-60	E- 9	90116-08064	B- 2
	D- 6	51L-2533A-00	D-13		D-14	1UA-82310-50	E-13	1AR-84327-00	E- 9		B-15
31K-23340-30	D- 6	51L-2533E-00	D-13	51L-25924-00	D-11	1M1-82370-21	E-13	29L-84330-00	E- 9	90116-08232	B-15
156-23411-00	D- 4	1UA-25338-20-FH	D-12		D-11	1UA-82501-00	E-13	341-84332-60	E- 9	90116-08318	B- 2
183-23411-00	D- 4	29L-25364-00	D-12		D-14	1T2-82530-00	E-12	198-84334-60	E- 9	90116-08365	B-14
156-23412-00	D- 4	29L-25366-00	D-12	33M-25927-00	D-14	1L9-82540-00	E-13	4E2-84347-00	E- 9	90116-08388	B- 2
183-23412-00	D- 4	4L0-25377-00	D-12	1JF-26121-00	D-15	1UA-82590-00	E-12	56Z-84366-00	E- 9	90116-08424	B- 2
4K0-23415-00	D- 4	51L-25381-01	D-12	1JF-26122-00	D-15	5A8-82591-00	D-15	56Z-84367-00	E- 9	90119-06042	C-12
1UA-23435-00-98	D- 4	51L-25388-00	D-12	31A-26241-00	D-15	29L-82911-01	E-11	56Z-84368-00	E- 9	90119-06044	C-11
164-23462-00	D- 4	29L-25398-00	D-10	31A-26242-00	D-15	51J-83310-00	E- 7	2F9-84375-00	E- 9		C-14
2H9-23469-00	D-15		D-12	36Y-26243-00	D-15	51J-83320-00	E- 7	56Z-84388-00	E- 9	90119-06095	C-11
1UA-24110-00-04	D- 7	29L-25398-10	D-10	29L-26246-00	D-15	1VU-83330-00	E- 7	29L-84395-00	E- 9	90123-08083	D-15
1UA-24110-00-05	D- 7		D-12	2H7-26249-00	D-15	1VU-83332-00	E- 7	2F9-84397-01	E- 9	90149-06011	D- 7
29L-2416A-00	D- 8	29L-25398-20	D-10	1UA-26260-00	D-15	51L-83332-01	E- 7	56Z-84398-00	E- 9	90149-06153	E-11
1UA-24161-00	D- 7		D-12	1UA-26280-00	D-15		E- 7	47X-84710-E0	E-10	90149-06154	C-10
1WT-24161-00	D- 7	31K-25439-20-33	D-12	1UA-26290-00	D-15	1VU-83340-00	E- 7	31L-84714-00	E-10	90149-08094	C- 9
1A0-24181-00	D- 7	51L-25810-00	D-11	1UA-26335-00	D-15	1VU-83342-00	E- 7	47X-84721-00	E-10	90149-08143	C- 4
137-24181-00	C-10	51L-25810-10	D-11	50W-26396-00	C-12	4K0-83350-20	E-13	47X-84723-00	E-10	90149-08230	D-11
29L-24182-00	D- 7	51L-25810-50	D-14	5H0-26393-00	D-15	10V-83365-00	E- 7	47X-84735-00	E-10		D-14
3Y6-24183-00	D- 7	51L-25819-00-98	D-14	29L-27111-01-33	E- 4	1UA-83371-00	E-13	461-84744-00	E- 8	90149-10232	E- 4
1A0-24186-00	D- 7	29L-2582A-50	E- 5	109-27114-00	E- 4	1A0-83395-03	E-13	29L-84751-00	E-10	90153-06007	E- 6
12R-24186-00	D- 7	51L-25827-00	D-11	51L-27200-00	E- 4	1JF-83509-00	E- 8	449-85131-02	E-12	90157-05079	E- 3
1UA-24191-00	D- 7		D-11	1J3-27222-01	E- 4	1AR-83513-00	E- 8	1UA-85510-50	E- 6		E- 3
1UA-24240-00	D- 7	51L-25827-10	D-11	29L-27311-00-33	E- 4	1AR-83520-00	E- 8	1UA-85540-50	E-12	90157-06046	D- 7
1UA-24240-10	D- 7		D-11	1UA-27410-00	E- 3	1AR-83522-00	E- 8	1UA-85550-50	E- 6	90157-08066	E- 5
1UA-24311-00	D- 7	1UA-25831-00-33	D-11	46X-27413-00	E- 3	584-83523-00	E- 8	34X-85720-00	E-12	90159-03102	E- 8
29L-24311-00	B-13		D-14		E- 3	47X-83540-00	E- 8	1UA-85820-00	E-13	90159-06016	C- 4
1JK-24315-00	D- 8	1UA-25831-10-33	D-11	29L-27414-01	E- 3	584-83541-00	E- 8	1UA-85830-00	E-13	90159-06056	E- 5
29L-24316-00	C-14	341-25846-00	D-10		E- 4	11L-83550-00	E- 8	90101-06576	B-14	90159-06060	C-14
29L-24317-00	C-14	29L-25850-51	E- 5	1UA-27420-00	E- 3	57V-83570-F0	E- 8		B-14	90159-06084	C-15
1UA-24500-00	D- 7	36Y-25850-00	E- 2	1HX-27431-00	E- 3	1AR-83579-01	E- 8	90101-08592	D- 6	90170-06010	E-11
2W6-24512-00	D- 7	1AE-25852-00	E- 2	1HX-27437-00	E- 3	1AR-83590-00	E- 8	90101-14654	C-15	90170-06289	C- 9
46X-24524-00	D- 7	1A1-25852-00	E- 5		E- 4	11H-83591-00	E-13	90105-08284	E- 3	90170-08029	C- 9
3H3-24534-00	D- 7	36Y-25854-00	E- 2	1HX-27441-00	E- 3	1AR-83611-00	E- 8		E- 4	90170-16182	C- 4
4X8-24565-00	D- 7	360-25854-00	E- 5	1UA-27442-00	E- 3	29L-83912-01	E-11	90105-10308	D-11	90170-20320	C- 4
1TV-24602-00	D- 7	360-25855-01	E- 5	1UA-27443-00	E- 3	31A-83913-00	E-11	90105-10363	D-14	90171-12005	D-10

NUMERICAL INDEX

PART NO.	GRID NO.	PART NO.	GRID NO.	PART NO.	GRID NO.	PART NO.	GRID NO.	PART NO.	GRID NO.	PART NO.	GRID NO.
90171-14020	D-12	90208-16019	C- 4	90430-06166	B- 2	90480-19453	C-12	92506-06020	C- 2	93102-32298	D-12
90179-05523	C-11	90209-06186	D- 7	90445-05203	B- 8	90501-06022	C- 8		E-10	93102-35369	C- 7
90179-06520	C-12	90209-08249	E- 3	90445-05765	B- 8	90501-10312	E-11	92506-06030	C- 2	93103-10147	B- 5
90179-08299	B- 2		E- 4	90445-08336	E-12	90501-12743	E- 3	92506-06040	C- 2	93103-25108	B- 4
90179-08316	D-15	90209-21105	C- 6	90445-09012	B-13		E- 3	92506-06055	C- 2	93103-40077	B- 4
90179-08343	B- 2		C- 6	90445-11763	B-13	90501-23138	C- 4	92701-06015	C- 8	93105-45017	D-10
90179-12323	E- 6	90209-22292	B- 4	90445-12718	B-11	90506-20192	E- 4	92706-06030	D-15	93106-20002	D-10
90179-18020	C- 7	90214-15020	C- 3	90446-07112	B-15	90506-35349	E- 4	92901-04600	E- 5	93108-23010	B- 3
90179-25495	D- 4	90215-08174	C- 9	90460-27219	B- 6	90507-29032	E- 4	92901-05100	B- 8		B- 3
90185-08097	B-14	90215-10253	B- 9		B- 7	90508-16599	C- 4	92901-05600	D- 2	93109-18020	C-15
	E- 3	90215-20223	C- 4		B- 7	90508-26452	C- 8	92901-06200	B-15	93109-20029	C-15
	E- 4	90215-21239	C- 7		B- 7	90508-30051	C- 3		D- 2	93210-07100	B- 8
90185-08113	D-12	90240-08013	E- 4	90460-44108	B-10	90508-32374	C- 9		E-12	93210-15620	E- 5
90185-10037	E- 4	90250-08017	C- 8	90460-49058	B-10	90560-12171	C- 9	92901-06600	B-10	93210-17239	B- 6
90185-10115	E- 3	90280-05033	B- 4	90460-68230	B-10	91026-08050	D- 4		B-10	93210-19123	C- 2
	E- 3	90282-07023	C- 4	90462-08070	C- 2	91311-06030	D- 2		E-12	93210-29147	E-13
90185-14070	C-15	90334-10014	C- 8	90462-08071	C- 2	91316-03016	E- 8	92901-08200	C- 4	93210-30640	B- 2
90185-14137	C-15	90338-05038	B-15	90462-16130	B-15	91316-04020	B- 3		E- 9		B- 3
90201-052E2	E- 8	90338-16029	B-15	90464-12027	C-11	91316-05010	B- 3	92901-08600	D-12	93210-30734	B- 3
90201-060A3	B- 6	90338-19166	D-15	90465-06094	B-15	91316-05012	B- 2	92901-12200	D-10		B- 3
90201-06042	E- 6	90340-14010	B-15	90465-08125	B-15		B- 2	92902-04100	B-12	93210-48530	D-12
90201-06052	E-10	90380-20123	D- 3	90465-16239	C- 5		B- 3		E- 5	93305-20502	C- 6
90201-06059	E-10	90383-12022	B-15	90467-08003	C-14	91316-06016	D-15	92906-04100	E- 8	93306-30003	B- 5
90201-06067	B- 6	90386-18118	C-15	90467-08075	D- 8	91316-06020	B- 6	92906-04600	E- 8	93306-30109	D-10
	E-13	90386-18136	C-15	90467-09006	D- 8		B- 6		E-11	93306-30206	D-12
90201-062A8	E-10	90386-20134	C-15	90467-10008	B-12	91316-06025	B-10	92906-05100	E- 8	93306-30416	D-12
90201-063J2	E-10	90387-06065	D- 2		C-14		E- 2	92906-06100	B- 2	93306-30504	C- 7
90201-06380	B- 6	90387-064H8	E- 3	90467-10041	B-13	91316-08025	D-15		E- 2	93306-30548	B- 4
	E- 8		E- 3		D- 8	91316-10030	E- 3		E-10	93306-30549	B- 4
90201-08083	E- 4	90387-06676	E- 8	90467-13083	B- 6		E- 4		E-11	93310-316H6	B- 4
90201-08624	B- 8	90387-06694	E-10	90467-14057	E- 5	91401-16012	E- 4	92906-06600	B- 2	93310-522L4	B- 4
90201-08784	B- 5	90387-07037	B-11	90467-20085	B-10	91401-20015	E- 3		B-14	93311-22027	C- 6
90201-10118	E- 2	90387-07390	B- 6	90468-02033	B- 8		E- 3		B-14	93311-42045	C- 6
	E- 5	90387-07392	B- 6		B- 8	91401-30025	D-10	92906-08600	D- 4	93315-11720	C- 4
90201-10126	C-15	90387-106H5	D- 3		B- 9	91401-30030	D-13	92990-03100	B-10	93315-23612	C- 8
	D- 3	90387-123A9	D-10	90468-08086	B- 8	91701-06045	E- 3		E- 8	93320-32403	C-15
90201-12191	C-15	90387-125A8	C- 9	90468-26091	C- 3		E- 3		E- 8	93430-08036	B- 8
90201-122A7	B- 2	90387-12670	D-10	90480-01148	E-13	92501-06012	C- 6	92990-06100	D- 9		C- 8
	C- 9	90387-127H2	C-15	90480-12014	B- 6		E-12		D- 9	93440-19083	B- 7
90201-12729	D- 3	90387-144H4	C-15		C-12	92501-06014	B- 5	92990-06200	E-12	93440-25084	C- 6
90201-161J3	C-15	90387-154A0	D-12		C-12		E-12		E-13		C- 6
90201-17327	C- 4	90387-156L5	D-13		C-14	92501-06025	E-13	92990-08100	E- 9	93440-34025	C- 8
90201-20266	C- 6	90387-257N4	C- 7	90480-12053	C-12	92501-06055	B-10	92990-10600	C-10	93440-52009	C- 6
90201-20276	C- 6	90401-10095	E- 2	90480-13426	C-12	92501-06075	B-10	93101-10002	B- 8	93501-04004	E- 3
90201-25490	C- 6	90401-10096	E- 2	90480-15363	B- 6	92502-06016	D- 9	93101-20048	C- 3		E- 4
	C- 7		E- 5	90480-16233	B-10		D- 9	93102-12106	C- 9	93501-04011	D- 4
90202-06010	D- 7	90413-07023	B-13	90480-16284	B- 6	92506-06016	B- 6	93102-17004	C- 4	93505-32002	B- 8
90206-12074	C- 9	90430-04004	B- 8	90480-18276	E-10	92506-06020	C- 2	93102-22014	D-12	93515-32029	C- 4

NUMERICAL INDEX

PART NO.	GRID NO.	PART NO.	GRID NO.	PART NO.	GRID NO.	PART NO.	GRID NO.	PART NO.	GRID NO.
93603-22028	B- 5	97301-06016	B- 6	98701-05016	C- 8				
	B- 8	97301-06018	B-11	98702-05012	E-13				
93604-12037	C- 8	97306-06020	E-10	98706-04012	E- 2				
93700-06004	C-15	97306-06025	E-11	98901-04008	B- 8				
93900-00015	D-10	97311-06045	B-15	98906-05016	C-11				
	D-12	97311-06060	B-15	98906-06016	C-13				
93900-00018	D-10	97311-06090	B-15	99001-07600	B- 5				
	D-12	97316-06020	C- 9	99009-12400	C- 9				
94109-184J2	D-10	97326-06018	B- 2	99009-15400	C- 3				
94109-187J7	D-10	97326-08030	C- 3	99009-20400	C- 6				
94111-184J3	D-12	97701-50525	B-10		C- 6				
94111-187M4	D-12	97702-60116	E-13	99510-10114	B- 2				
94580-93106	D-12	97702-60520	E-12	99510-12016	B-15				
94701-00188	B- 2	97706-40516	B- 7		C- 2				
95021-08016	C-10	97706-40620	E- 7						
	C-10		E- 7						
95021-10115	C-10		E- 7						
95021-10150	C-10		E- 7						
95023-06016	C-11	97706-50512	C- 2						
95026-08030	D- 4	97780-60116	E-12						
95301-05600	B- 8	98001-10040	C-10						
95301-08600	D-12		C-10						
	E- 9	98002-06010	C-10						
95301-08700	E- 4	98002-06018	E-13						
95302-06600	E-10	98002-08030	D- 7						
	E-10	98006-06008	D- 7						
95306-05800	E- 8	98006-06010	E- 5						
95306-06600	E- 8	98006-06025	E- 2						
95306-06700	C- 9	98006-08012	E-13						
95306-08800	D- 4	98006-08035	C-12						
95311-08700	C- 4	98501-03008	B-10						
95316-12700	E- 7	98501-03012	E- 8						
95601-12100	C-15	98501-05010	B-15						
95602-10100	C-15		D- 2						
	D- 3		D- 7						
95606-06100	E-11	98501-05016	B- 8						
95701-08500	B-15	98502-04008	B-12						
95701-10500	C-10	98506-03008	D- 7						
	C-10	98506-04008	E- 8						
95702-06100	E-13	98506-04018	E-11						
95706-06100	E-11	98506-05012	E- 9						
95806-06020	B- 6	98506-05014	C- 2						
95806-06025	B- 6	98506-05035	E-11						
95806-08012	C-10	98506-05040	E-11						
95806-08030	E- 9	98506-05045	E-11						
95826-06010	B- 2	98511-04012	E- 5						
97001-06025	E- 2	98511-04016	B-12						
97301-06010	C- 5	98701-05012	C- 8						

INDEX

(INDIVIDUAL SPEC.)

NUMERICAL INDEX

PART NO.	GRID NO.	PART NO.	GRID NO.	PART NO.	GRID NO.	PART NO.	GRID NO.	PART NO.	GRID NO.
33E-12467-00	E-15	4E2-84347-00	F- 6						
1UA-14710-10	F- 9		F-11						
1UA-14720-10	F- 9	5G2-84366-00	F- 6						
1WV-21610-00	F- 2		F-11						
1XA-21610-00	F- 5	5G2-84367-00	F- 6						
	F-10		F-11						
1XG-24730-00	F- 2	5G2-84368-00	F- 6						
1XG-24730-20	F- 2		F-11						
1UA-24731-00	F- 2	2F9-84375-00	F- 6						
1UA-24731-20	F- 2		F-11						
1UA-27311-00-33	F- 2	5G2-84388-00	F- 6						
	F- 5		F-11						
	F-10	29L-84395-00	F- 6						
4X7-82151-00	F- 3		F-11						
	F- 6	2F9-84397-01	F- 6						
	F-11		F-11						
5G2-82151-00	F- 3	5G2-84398-00	F- 6						
	F- 7		F-11						
	F-12	20G-85110-00	F- 3						
1A0-82161-00	F- 3	4Y3-85590-M0	F- 3						
	F- 6		F- 7						
	F-11		F-12						
33E-82566-00	F- 3	90101-06576	F- 9						
	F- 7		F- 9						
	F-12	92906-06600	F- 9						
1UA-82590-10	F- 3		F- 9						
	F- 6	92990-05100	F- 6						
	F-11		F-11						
14T-84124-00	F- 6	92990-05200	F- 6						
	F-11		F-11						
10X-84131-00	F- 6	92990-06100	F- 3						
	F-11		F- 7						
457-84146-85	F- 6		F-12						
	F-11	92990-06600	F- 3						
1JF-84303-G0	F- 6		F- 7						
	F-11		F-12						
1AR-84315-00	F- 6	95302-05600	F- 6						
	F-11		F-11						
31K-84320-G0	F- 6	95702-05500	F- 3						
	F-11	97702-60520	F- 3						
1AR-84327-00	F- 6		F- 7						
	F-11		F-12						
29L-84330-00	F- 6	98506-05012	F- 6						
	F-11		F-11						
341-84332-60	F- 6	98706-05016	F- 3						
	F-11		F- 7						
198-84334-60	F- 6		F-12						
	F-11								

COPY RIGHT: ALL RIGHTS RESERVED
NO PART OF THIS PUBLICATION MAY BE
REPRODUCED WITHOUT PERMISSION.



YAMAHA

YAMAHA MOTOR CO., LTD.
2500 SHINGAI IWATA-SHI SHIZUOKA-KEN JAPAN

PRINTED IN JAPAN
First edition Jan., 1986

T6